



SCD32 THRU SCD36

SURFACE MOUNT SCHOTTKY BARRIER RECTIFIER

Reverse Voltage - 20 to 60 Volts

Forward Current - 3.0 Ampere

PATENTED

SCD/2010

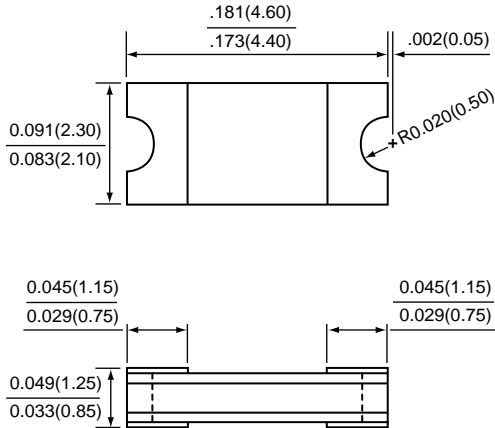

*Dimensions in inches and (millimeters)

SuperChipTM

FEATURES

- * Plastic package has Underwriters Laboratory Flammability Classification 94V-0
- * For surface mounted applications
- * Low profile package
- * Built-in strain relief
- * Metal to silicon rectifier , majority carrier conduction
- * Low power loss , High efficiency
- * High current capability , low VF
- * High surge capacity
- * For using in low voltage high frequency switching power supply, inverters , free wheeling , and polarity protection applications

MECHANICAL DATA

Case : Packed with FRP substrate and epoxy underfilled
Terminals : Solder plated , solderable per MIL-STD-750, Method 2026
Polarity : Laser marking
Weight : 0.02 gram

MAXIMUM RATINGS AND ELECTRICAL CHARACTERISTICS

<i>Ratings at 25 °C ambient temperature unless otherwise specified.</i>	SYMBOLS	SCD32	SCD33	SCD34	SCD35	SCD36	UNITS
Maximum repetitive peak reverse voltage	VRRM	20	30	40	50	60	Volts
Maximum RMS voltage	VRMS	14	21	28	35	42	Volts
Maximum DC blocking voltage	VDC	20	30	40	50	60	Volts
Maximum average forward rectified current (SEE FIG.1)	I (AV)	3.0					Amps
Peak forward surge current 8.3ms single half sine-wave superimposed on rated load (JEDEC Method)	IFSM	80					Amps
Maximum instantaneous forward voltage at 2.0 A (NOTE 1)	VF	0.50			0.70		Volts
Maximum DC reverse current (NOTE 1) @T _J =25°C at rated DC blocking voltage @T _J =100°C	IR	0.5					mA
		20			10		
Typical thermal resistance (NOTE 2)	R θJA R θJL	55 17					°C / W
Operating junction temperature range	TJ	-55 to +125			-55 to +150		°C
Storage temperature range	TSTG	-55 to +150					°C

NOTES : (1) Pulse test with PW=300usec , 1% duty cycle.
 (2) Mounted on P.C. board with 0.2 x 0.2"(5.0 x5.0mm) copper pad areas.

RATINGS AND CHARACTERISTIC CURVES SCD32 THRU SCD36

FIG.1 - FORWARD CURRENT DERATING CURVE

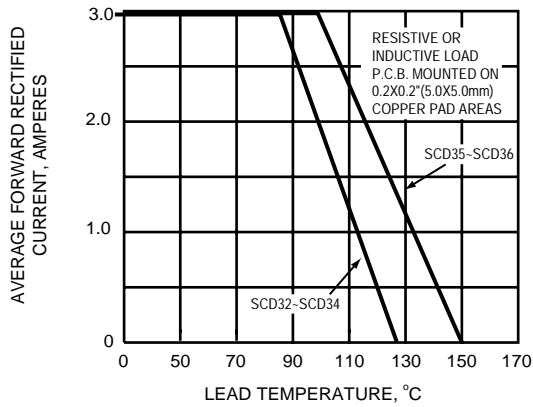

FIG.2 - MAXIMUM NON-REPETITIVE PEAK FORWARD SURGE CURRENT

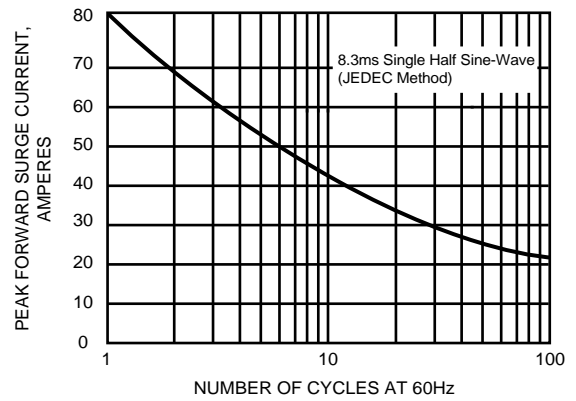

FIG.3 - TYPICAL INSTANTANEOUS FORWARD CHARACTERISTICS

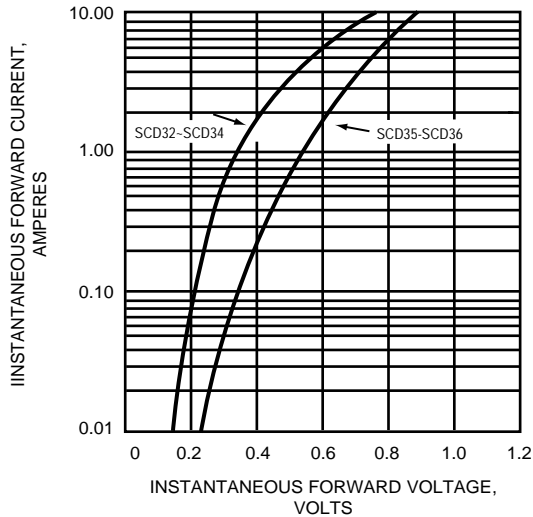

FIG.4 - TYPICAL REVERSE CHARACTERISTICS

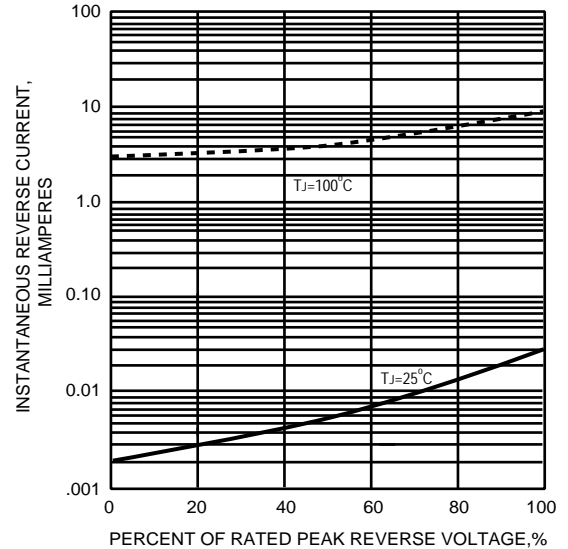

FIG.5 - TYPICAL JUNCTION CAPACITANCE

