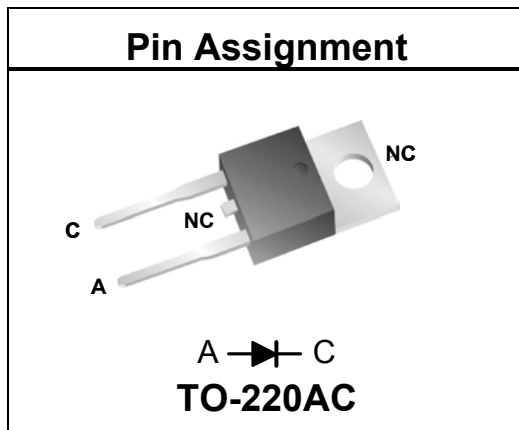


# 600V, 3A Qspeed “Q-Series” PFC Rectifier

## Product Summary

$I_{F(AV)}$	3	A
$V_{RRM}$	600	V
$Q_{RR}$ (Typ at 125°C)	17.2	nC
$I_{RRM}$ (Typ at 125°C)	1.28	A
Softness $t_b/t_a$ (Typ at 125°C)	1.5	



## RoHS Compliant

Package uses Lead-free plating and Green mold compound.

## General Description

Using advanced Silicon technology, the Q-Series power rectifier is specifically designed to replace SiC Schottky Diodes in PFC Boost applications where it will provide similar gains in efficiency and power density, but at a lower cost and with the proven long term reliability of Silicon.

Utilizing proprietary Qspeed Silicon technology, this device offers extremely low reverse recovery current. Its soft recovery reduces electrical stress on surrounding circuit elements (especially the switching transistors), and helps to reduce heat, lower unnecessary component guard-banding and snubbing, and increase efficiency.

## Applications

- Power Factor Correction (PFC) Boost Diode
- AC/DC power supplies and adapters
- Freewheeling diodes

## Features

- Enables PFC operation beyond 200kHz
- Low EMI, Low  $Q_{RR}$ , Low  $I_{RRM}$
- High  $dI/dt$  capable (1000A/us)
- Soft recovery
- Snubberless operation
- Internally self-isolated – needs no isolation pad

## Absolute Maximum Ratings

Absolute maximum ratings are the values beyond which the device may be damaged or have its useful life impaired. Functional operation under these conditions is not implied.

Symbol	Parameter	Conditions	Rating	Units
$V_{RRM}$	Peak repetitive reverse voltage		600	V
$I_{F(AV)}$	Average forward current	$T_J = 150^\circ\text{C}$ , $T_C = 122^\circ\text{C}$	3	A
$I_{FSM}$	Non-repetitive peak surge current	60Hz, 1/2 cycle	30	A
$I_{FSM}$	Non-repetitive peak surge current	1/2 cycle of T=28us Sinusoid, $T_C=25^\circ\text{C}$	350	A
$T_J$	Maximum junction temperature		150	°C
$T_{STG}$	Storage temperature		-55 to 150	°C
	Lead soldering temperature	Leads at 1.6mm from case, 10 sec	300	°C
$V_{ISOL}$	Peak isolation voltage (leads-to-tab)	DC, + to tab	2500	V
$P_D$	Power dissipation	$T_C = 25^\circ\text{C}$	32	W

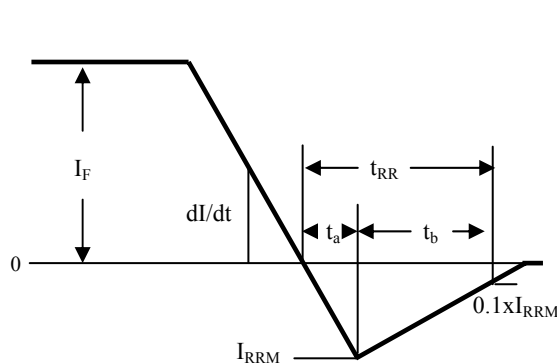
## Thermal Resistance

Symbol	Resistance from:	Conditions	Rating	Units
$R_{\theta JA}$	Junction to ambient	TO-220	62	°C/W
$R_{\theta JC}$	Junction to case	TO-220	3.85	°C/W

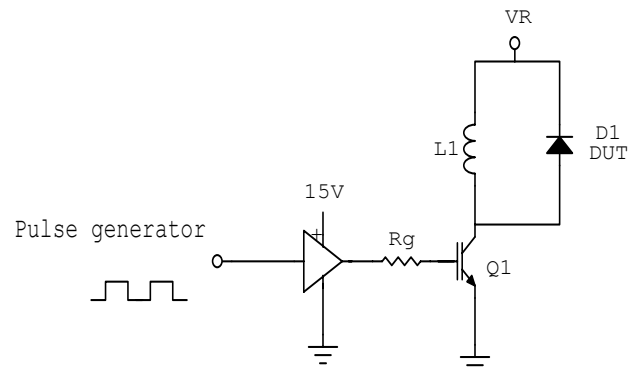
**Electrical Specifications** @T<sub>J</sub>= 25°C (unless otherwise specified)

Symbol	Parameter	Conditions	Min	Typ	Max	Units	
<b>DC Characteristics</b>							
I <sub>R</sub>	Reverse current	V <sub>R</sub> = 600V, T <sub>J</sub> = 25°C	-	-	20	μA	
		V <sub>R</sub> = 600V, T <sub>J</sub> = 125°C	-	0.25	-	mA	
V <sub>F</sub>	Forward voltage	I <sub>F</sub> = 3A, T <sub>J</sub> = 25°C	-	2.77	3.1	V	
		I <sub>F</sub> = 3A, T <sub>J</sub> = 150°C	-	2.3	-	V	
C <sub>J</sub>	Junction capacitance	V <sub>R</sub> = 10V, 1MHz	-	13	-	pF	
<b>Dynamic Characteristics</b>							
t <sub>RR</sub>	Reverse recovery time	dI/dt = 200A/μs V <sub>R</sub> =400, I <sub>F</sub> =3A	T <sub>J</sub> =25°C	-	9.3	13	ns
			T <sub>J</sub> =125°C	-	21.4	-	ns
Q <sub>RR</sub>	Reverse recovery charge	dI/dt = 200A/μs V <sub>R</sub> =400, I <sub>F</sub> =3A	T <sub>J</sub> =25°C	-	4.8	7.5	nC
			T <sub>J</sub> =125°C	-	17.5	-	nC
I <sub>RRM</sub>	Maximum reverse recovery current	dI/dt = 200A/μs V <sub>R</sub> =400, I <sub>F</sub> =3A	T <sub>J</sub> =25°C	-	0.85	1.1	A
			T <sub>J</sub> =125°C	-	1.28	-	A
S	Softness factor = $\frac{t_b}{t_a}$	dI/dt = 200A/μs V <sub>R</sub> =400, I <sub>F</sub> =3A	T <sub>J</sub> =25°C	-	0.8	-	
			T <sub>J</sub> =125°C	-	1.5	-	

Note to component engineers: Qspeed Q-Series rectifiers employ Schottky technologies in their design and construction. Component engineers therefore should plan their test setups to be similar to traditional Schottky test setups. (For further details, see Qspeed application note AN-300.)

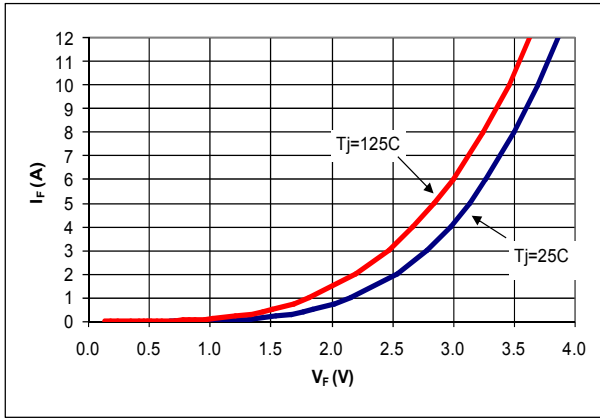


**Figure 1. Reverse Recovery Definitions**

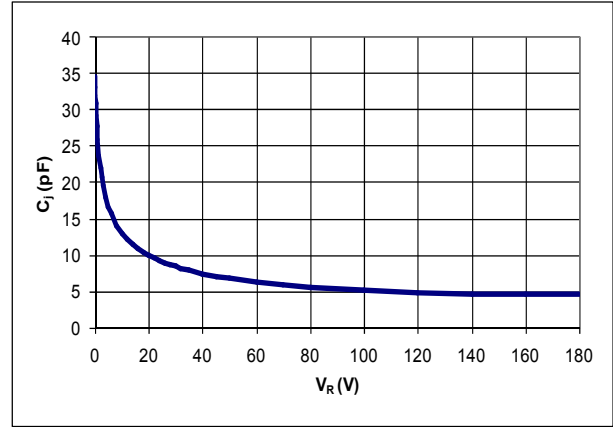


**Figure 2. Reverse Recovery Test Circuit**

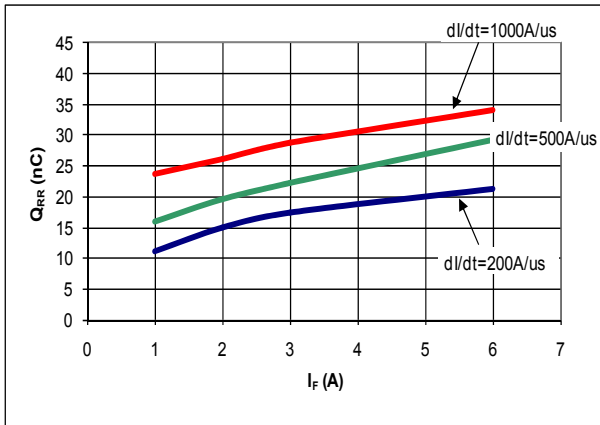
**Electrical Specifications @T<sub>J</sub>= 25°C (unless otherwise specified)**



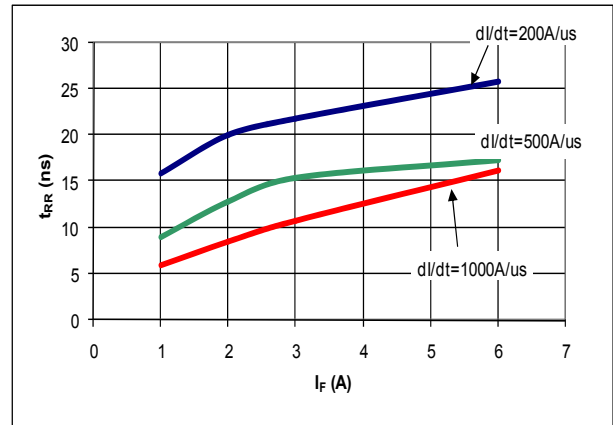
**Figure 3. Typical I<sub>F</sub> vs V<sub>F</sub>**



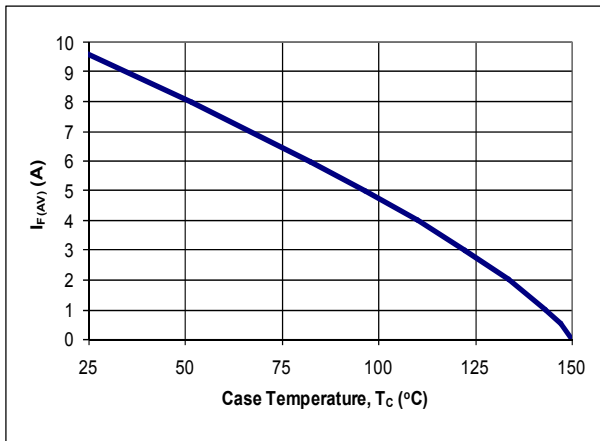
**Figure 4. Typical C<sub>j</sub> vs V<sub>R</sub>**



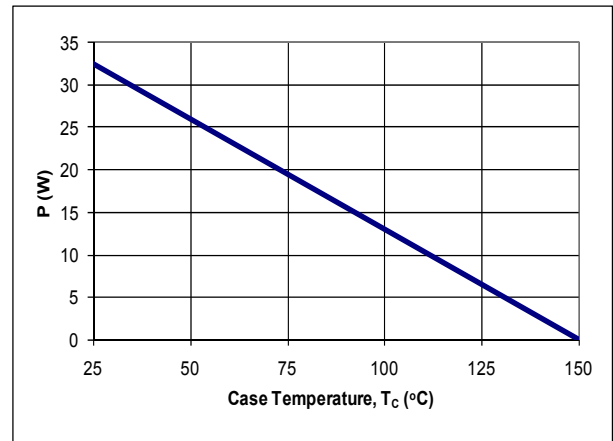
**Figure 5. Typical Q<sub>RR</sub> vs I<sub>F</sub> at T<sub>J</sub> = 125C**



**Figure 6. Typical t<sub>RR</sub> vs I<sub>F</sub> at T<sub>J</sub> = 125C**



**Figure 7. DC Current Derating Curve**



**Figure 8. Power Derating Curve**

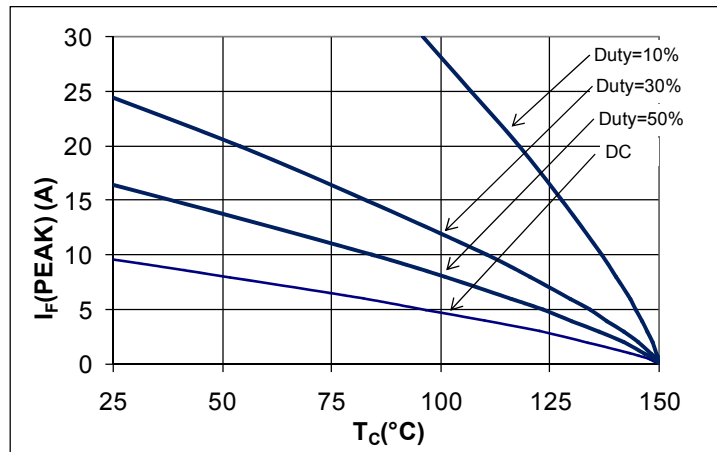


Figure 9. I<sub>F</sub>(PEAK) vs T<sub>C</sub>, f=70kHz.

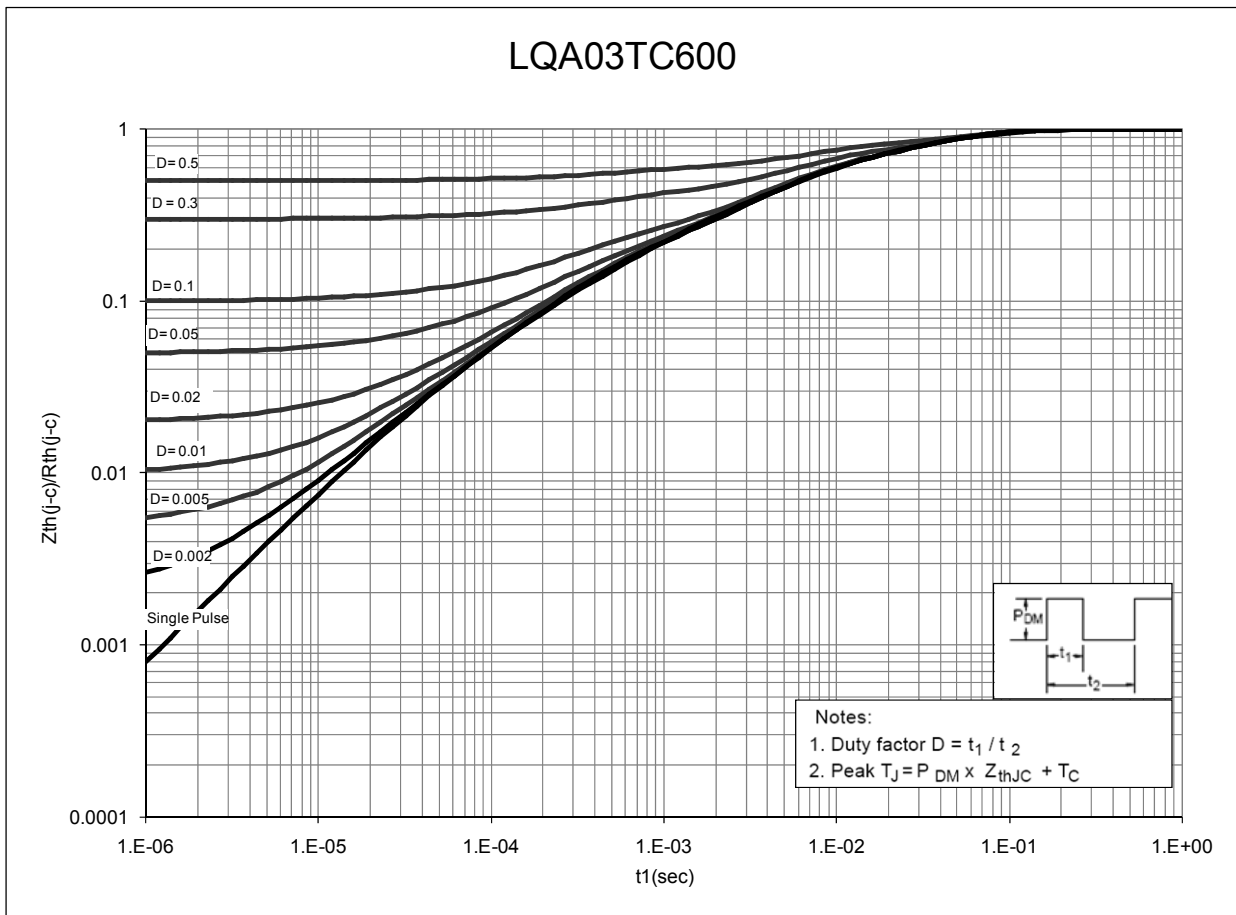
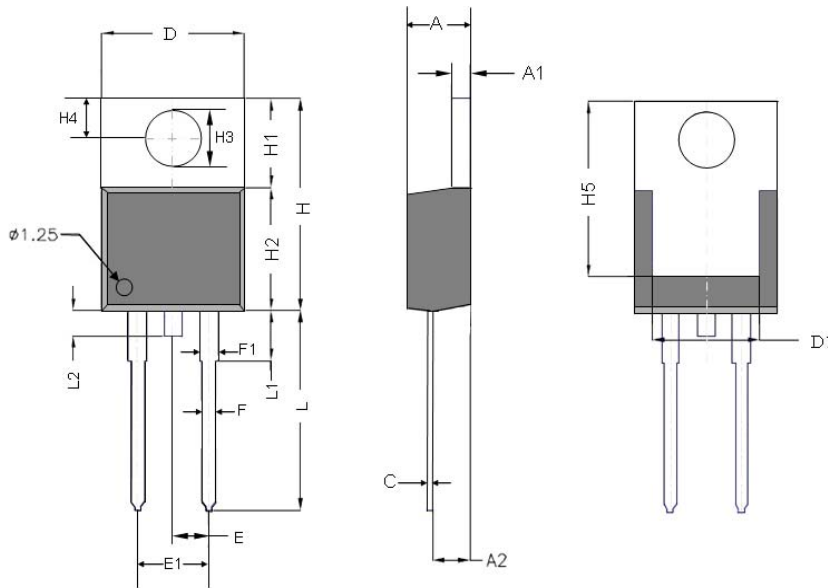


Figure 10. Normalized Maximum Transient Thermal Impedance

## Dimensional Outline Drawings



Dim	Millimeters		Inches	
	Min	Max	Min	Max
A	4.32	4.57	0.170	0.180
A1	1.14	1.40	0.045	0.055
A2	2.59	2.74	0.102	0.108
C	0.37	0.44	0.015	0.017
D	10.13	10.24	0.399	0.403
D1	7.57	7.68	0.298	0.302
E	2.49	2.59	0.098	0.102
E1	5.03	5.13	0.198	0.202
F	0.787	1.00	0.031	0.039
F1	1.23	1.36	0.048	0.054
H	14.71	15.31	0.579	0.603
H1	6.20	6.55	0.244	0.258
H2	8.51	8.76	0.335	0.345
H3	3.71	3.96	0.146	0.156
H4	2.54	2.79	0.100	0.110
H5	12.34	12.45	0.486	0.490
L	13.72	14.22	0.540	0.560
L1	---	6.35	---	0.250
L2	1.27	1.78	0.050	0.070

Controlling dimensions are in millimeters

## Ordering Information

Part Number	Package	Packing
LQA03TC600	TO-220AC	50 units/tube

### LIFE SUPPORT POLICY

QSPEED SEMICONDUCTOR PRODUCTS ARE NOT AUTHORIZED FOR USE AS CRITICAL COMPONENTS IN LIFE SUPPORT DEVICES OR SYSTEMS WITHOUT THE EXPRESS WRITTEN APPROVAL OF THE PRESIDENT OF QSPEED SEMICONDUCTOR CORPORATION. As used herein:

1. Life support devices or systems are devices or systems which, (a) are intended for surgical implant into the body or (b) support or sustain life, and (c) whose failure to perform when properly used in accordance instructions for use provided in the labeling, can be reasonably expected to result in a significant injury of the user.
2. A critical component in any component of a life support, device or system whose failure to perform can be reasonably expected to cause the failure of the life support device or system, or to affect its safety or effectiveness.