

Low-saturation, Low-voltage 2 channels Bi-directional Motor Driver

Description

The FP5501 is a monolithic IC for low-saturation bi-directional low cost and high efficiency miniature two DC motor or stepper motor applications, such as driving shutter (DC actuator), auto-focus (stepper motor), iris (stepper motor) and accurate zoom (stepper motor) on cameras, vibration on mobile phone and other motor applications on portable devices.

Features

- Low voltage operation ($V_{CC\ min} = 1.8V$)
- Full- and half-stepping capability
- Low saturation voltage(Upper + low transistor residual voltage; 0.46V typ. at 400mA)
- Low input current
- Low operating current, sleep mode with zero current drain
- Dead-zone protection
- High output sinking and driving capability
- Small, thin, highly reliable package (TDFN-10)
- Thermal shutdown protection

Applications

- Stepper Motor
- DSC
- Camera Module
- Motor Application on Portable Devices

Pin Assignments

Package (TDFN-10)

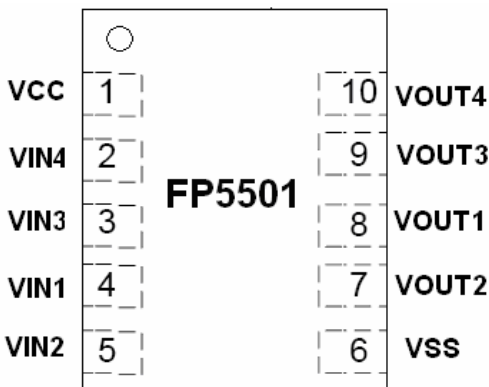
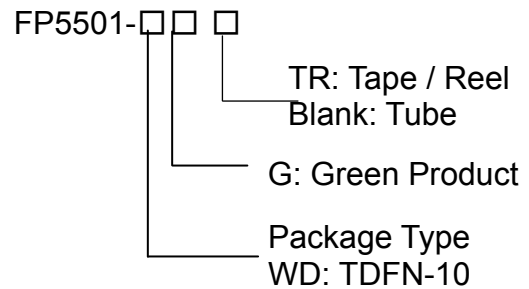

Figure 1. Pin Assignment of FP5501 (Top View)

Ordering Information



FITIPOWER DCC
CONTROL COPY

Block Diagram & Application Circuit

1. Shutter & Iris application

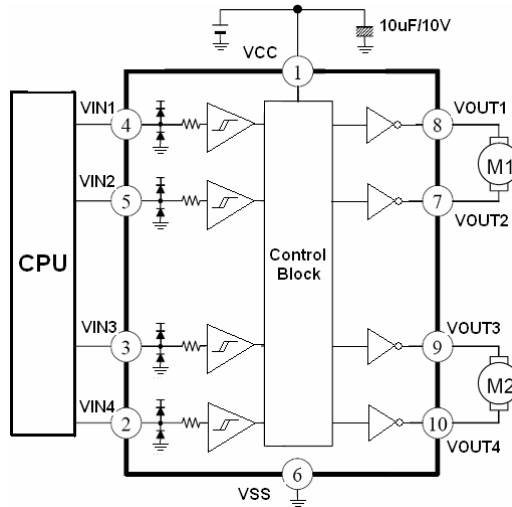

Figure 1a. Dual DC Motor Application

2. Stepping motor for 1-2 phase excitation

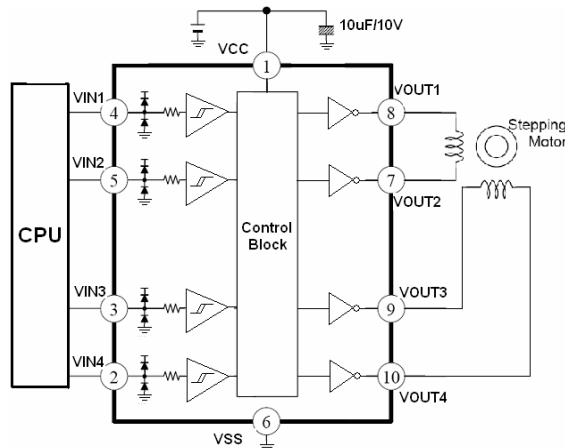

Figure 1b. Stepper Motor Application

3. Typical single dc motor control (paralleled outputs)

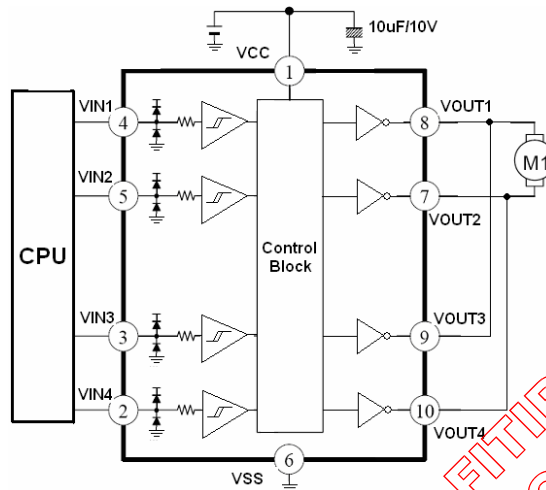

Figure 1c. Single (paralleled) DC Motor Application

FITIPOWER DCC CONTROL COPY

Functional Pin Description

Pin Num.	Pin Name	Pin Function	Pin Num.	Pin Name	Pin Function
1	VCC	Power supply pin.	6	VSS	Ground pin.
2	VIN4	Input pin.	7	VOUT2	Output sinking or driving current pin.
3	VIN3	Input pin.	8	VOUT 1	Output driving or sinking current pin.
4	VIN1	Input pin.	9	VOUT 3	Output sinking or driving current pin.
5	VIN2	Input pin.	10	VOUT 4	Output driving or sinking current pin.

Block Diagram

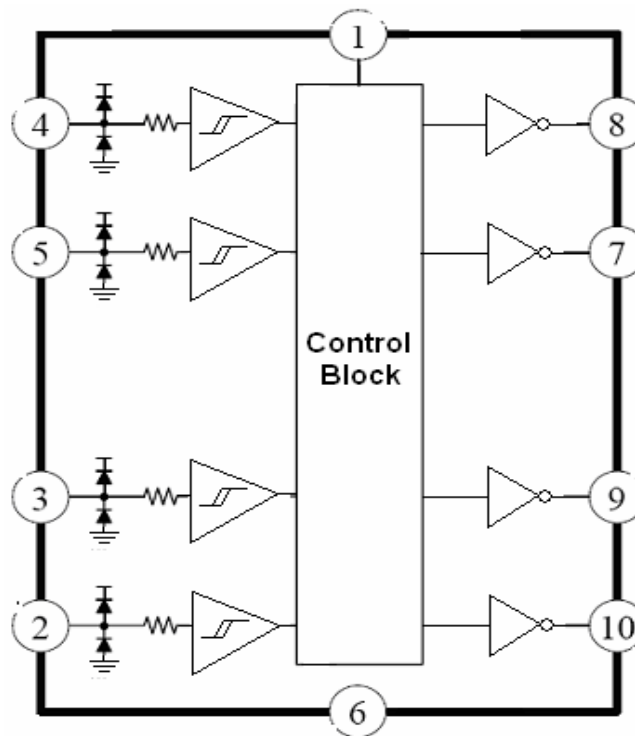

Figure 2. Block Diagram of FP5501

Absolute Maximum Ratings:

• VCC to VSS -----	- 0.3V to + 5.5V
• VIN and VOUT to VSS -----	- 0.3V to + (0.4V+ VCC)
• Output Current per Channel *1-----	0mA to 400mA
• Continuous Power Dissipation -----	486mW
• Junction Temperature -----	+ 150°C
• Storage Temperature Range-----	- 65°C to + 150°C
• Lead Temperature (Soldering, 10sec.) -----	260°C
• ESD (Human Body Model) *2-----	4000V

*1: Output current rating may be limited by ambient temperature and heat sinking. Under any set of conditions, do not exceed the specified.

*2: ESD caution: ESD (electrostatic discharge) sensitive device. Electrostatic charges as high as 4000V readily accumulate on the human body and test equipment and can discharge without detection. Although this product features proprietary ESD protection circuitry, permanent damage may occur on devices subjected to high energy electrostatic discharges. Therefore, proper ESD precautions are recommended to avoid performance degradation or loss of functionality.

Recommended Operating Conditions:

•Supply Voltage VCC to VSS -----	1.8V to 5.5V
•Maximum Output Drop Voltage(400mA Output Current)-----	0.46V
•Operation Temperature Range -----	-40°C to +125°C

Electrical Characteristics:

(Unless otherwise noted, $T_A = 25^\circ\text{C}$ & $V_{CC} = 3\text{V}$)

Parameter	Symbol	Conditions	Min.	Typ.	Max.	Unit
Supply Voltage	V_{CC}	-	1.8	3.0	5.5	V
Supply Current ($I_{CC} + I_{SS}$)	I_{CC0}	$V_{VIN1}, V_{VIN2}, V_{VIN3}, V_{VIN4} = 0\text{V}$	-	0.1	10	μA
	I_{CC1}	$V_{VIN1}, V_{VIN2}, V_{VIN3}, V_{VIN4} \neq 0\text{V}$	-	0.15	0.4	mA
VIN 1 / VIN 2 / VIN3 / VIN4 Input Terminal ($T_J = 25^\circ\text{C}$)						
Input Voltage "H"	V_{INH}	-	$0.5 \cdot V_{CC}$	-	$V_{CC} + 0.4$	V
Input Voltage "L"	V_{INL}	-	-0.4	-	$0.2 \cdot V_{CC}$	V
Input Voltage Hysteresis	V_{Hsy}	-	-	0.42	-	V
Input Current "H"	I_{INH}	$V_{IN} = V_{CC}$	-	-	5	μA
Input Current "L"	I_{INL}	$V_{IN} = 0\text{V}$	-	-	5	μA
VOUT 1 / VOUT 2 / VOUT 3 / VOUT 4 Output Terminal ($T_J = 25^\circ\text{C}$)						
Output Voltage (upper + lower)	V_{SAT1}	$I_{OUT} = 200\text{mA}$	-	0.22	0.4	V
	V_{SAT2}	$I_{OUT} = 400\text{mA}$	-	0.46	0.7	V
Thermal Protection Circuit						
Protection Temperature	T_{TSD}	$V_{VIN1}, V_{VIN2}, V_{VIN3}, V_{VIN4} = \text{H}$	-	150	-	$^\circ\text{C}$
Temperature Hysteresis	T_{Hsy}	$V_{VIN1}, V_{VIN2}, V_{VIN3}, V_{VIN4} = \text{H}$	-	25	-	$^\circ\text{C}$

Truth Table:

VIN1 or 3	VIN2 or 4	VOUT1 or 3	VOUT2 or 4	Mode
Low	Low	OFF	OFF	Standby
High	Low	High	Low	Forward
Low	High	Low	High	Reverse
High	High	---	---	Keep the previous mode(Forward / Reverse)

Truth Table test waves

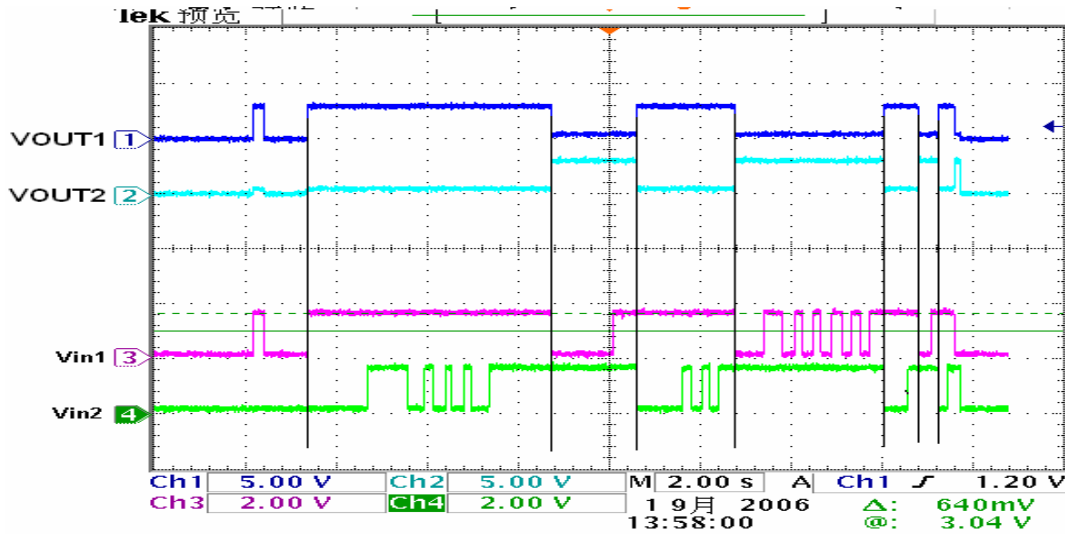

Figure 3. Truth Table test waves

Characteristic Performance Curve

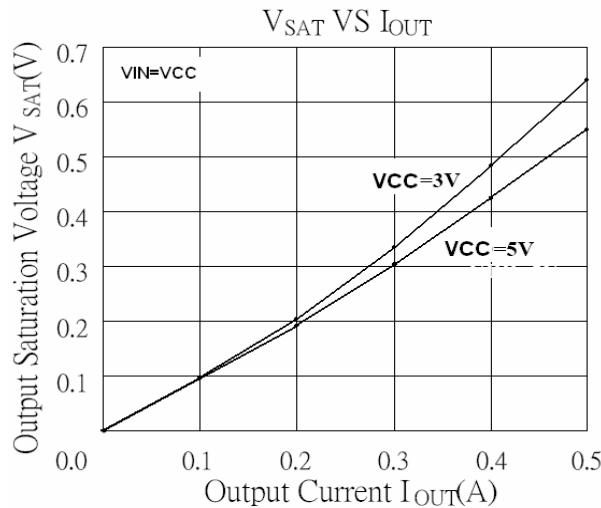

Figure 4a. Vsat VS Iout

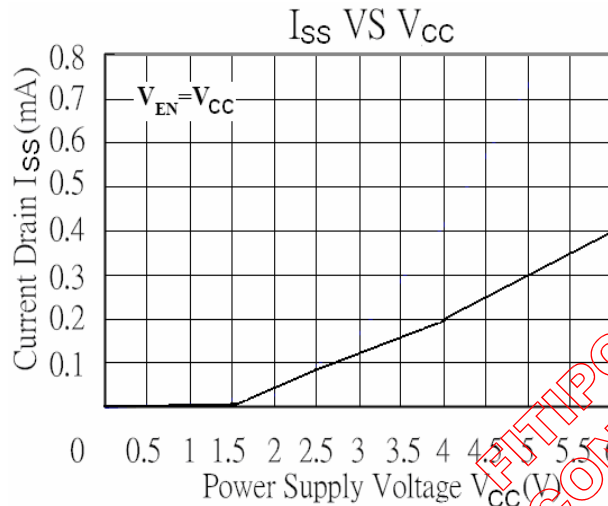

Figure 4b. Iss VS Vcc

Motor Operation Truth Table

INX *1				VOUT1 *2	VOUT2	VOUT3	VOUT4	Function	
Stepper Motor									
VIN1	VIN2	VIN3	VIN4	VOUT1 *2	VOUT2	VOUT3	VOUT4	Full Stepping	Half-stepping
0	0	0	0	OFF	OFF	OFF	OFF	Sleep Mode	Sleep Mode
1	0	1	0	H	L	H	L	Step1 *3	Step1
0	0	1	0	OFF	OFF	H	L	Step1_1 *4	Step2
0	1	1	0	L	H	H	L	Step2	Step3
0	1	0	0	L	H	OFF	OFF	Step2_1	Step4
0	1	0	1	L	H	L	H	Step3	Step5
0	0	0	1	OFF	OFF	L	H	Step3_1	Step6
1	0	0	1	H	L	L	H	Step4	Step7
1	0	0	0	H	L	OFF	OFF	Step4_1	Step8
DC Motor (Dual)									
VIN1 or VIN3		VIN2 or VIN4		VOUT1 *2	VOUT2	VOUT3	VOUT4	Function	
0		0		OFF	OFF	OFF	OFF	Sleep Mode	
1		0		H	L	H	L	Forward	
0		1		L	H	L	H	Reverse	
1		1		--	--	--	--	Keep the previous mode (Forward/Reverse)	
DC Motor (Single, Paralleled)									
VIN1 or VIN3		VIN2 or VIN4		VOUT1 *2	VOUT2	VOUT3	VOUT4	Function	
0		0		OFF	OFF	OFF	OFF	Sleep Mode	
1		0		H	L	H	L	Forward	
0		1		L	H	L	H	Reverse	
1		1		--	--	--	--	Keep the previous mode (Forward/Reverse)	

*1: 0 = logic low, $V_{in} < V_{IL}$ (max.); 1 = logic high, $V_{in} > V_{IH}$ (min.).

*2: H = voltage high, source driver on; L = voltage low, sink driver on.

*3: Two phase on stepper motor drive

*4: One phase on stepper motor drive

Function Description

Device Operation:

The FP5501 is a dual full-bridge low voltage motor driver capable of operating one stepper motor or up to two dc motors. MOSFET output stages substantially reduce the voltage drop and the power dissipation of the outputs of the FP5501 compared to typical drivers with bipolar transistors. Internal circuit protection includes thermal shutdown with hysteresis and crossover current protection. The FP5501 is designed for portable applications with a power-off (sleep mode) current of 100nA typical, and an operating voltage of 1.8V to 5.5V. The FP5501 logic inputs are 3 to 5V logic compatible.

In conditions where the logic supply voltage drops below 1.8V, both the sink and the source voltage

drop will increase beyond the specified values. In extreme cases, no power will be delivered to the motors. However, the device will not be damaged.

In stepping operation, the device can drive in either full- or half-step mode. The stepping mode is set by the signal pattern on the Inx terminals, as shown in the stepping timing diagrams.

Sleep Mode:

Pulling all inputs to 0.4V or less, sends the FP5501 to sleep mode, during which it draws 100nA typical.

Thermal Shutdown:

The FP5501 will disable the outputs if the junction temperature reaches 150 °C. When thermal shutdown is entered, after the junction temperature drops 15 °C, the outputs will be re-enabled.

Application Notes:

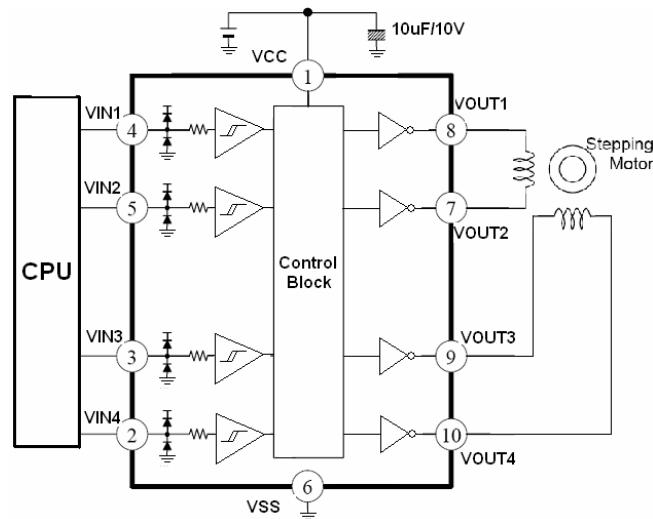

Figure 5a. Typical stepper motor control application

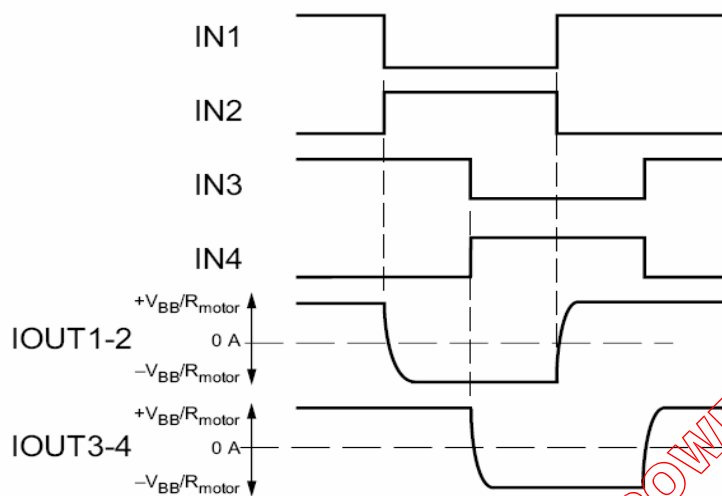

Figure 5b. Full step mode timing chart (two phase on)

FITIPOWER DCC
CONTROL COPY

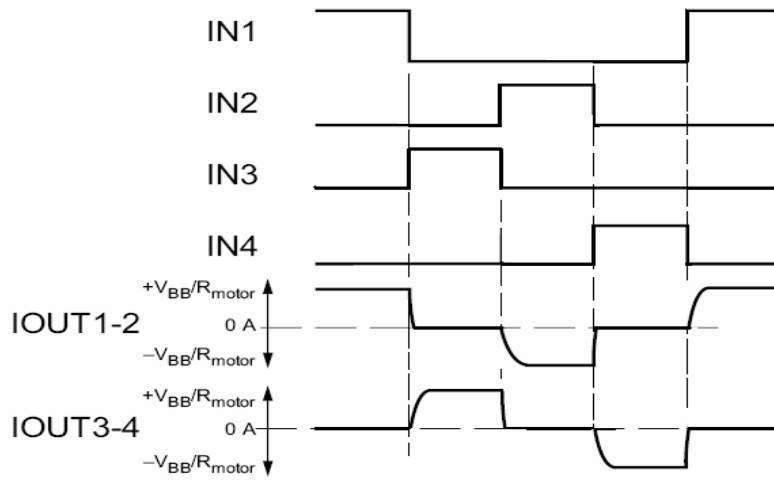

Figure 5c. Full step mode timing chart (one phase on)

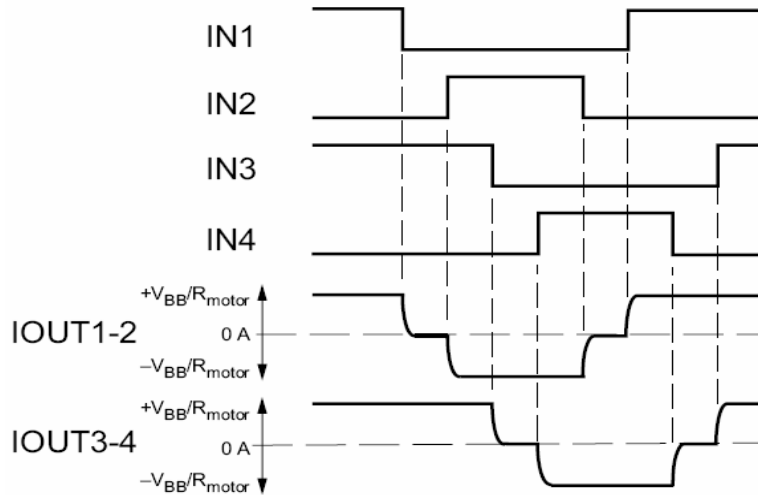

Figure 5d. Half step mode timing chart

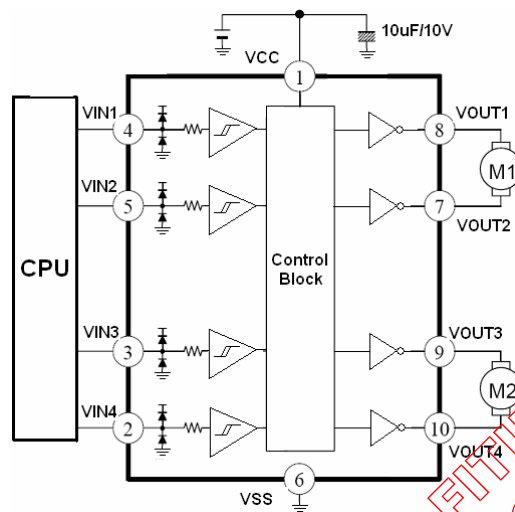

Figure 6. Typical dual dc motor control application.

Either IN1 or IN2 and be used to drive OUT1 and OUT2. Either IN3 or IN4 and be used to drive OUT3 and OUT4.

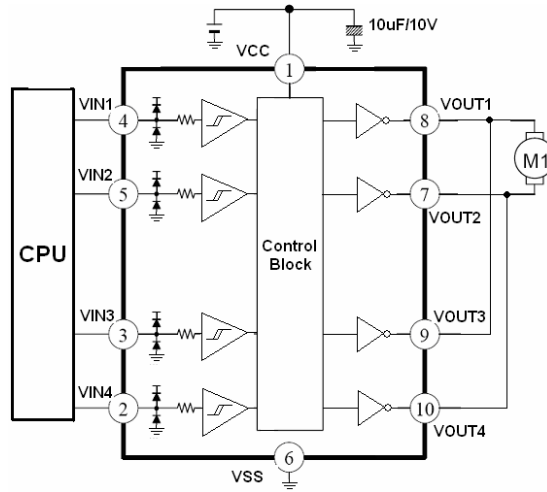

Figure 7. Typical single dc motor control application (paralleled outputs).

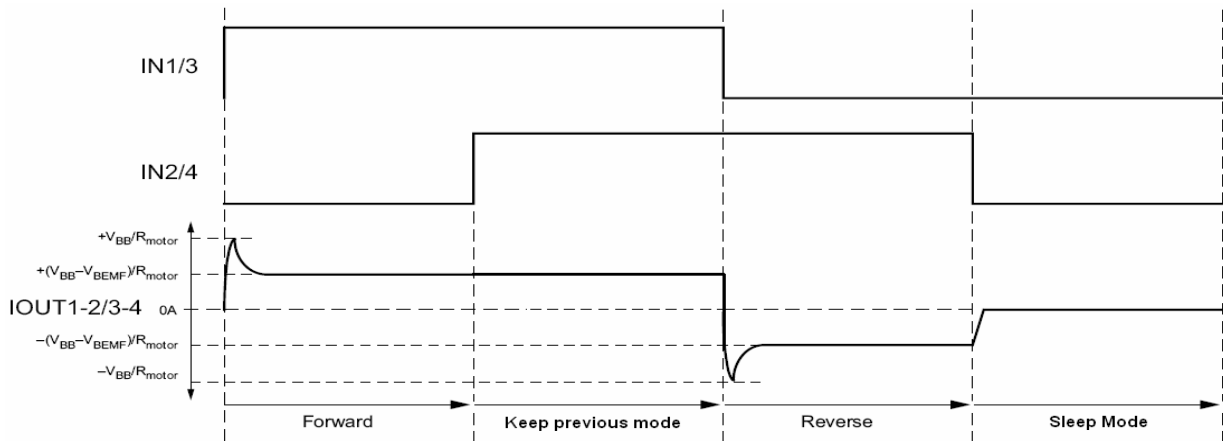
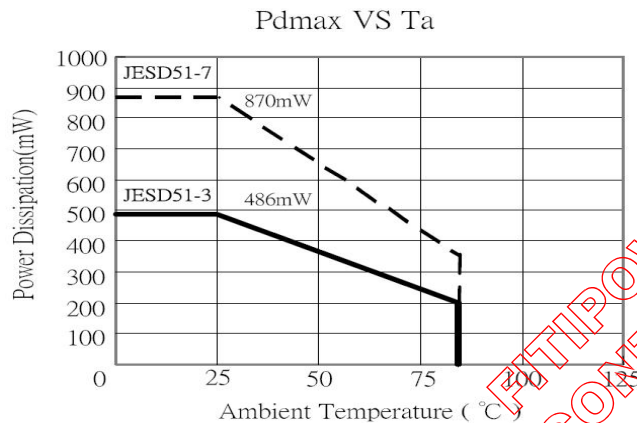

Figure 8. Typical dual dc motor control application (timing chart)

The power dissipated by the IC varies widely with the supply voltage, the output current, and loading. It is important to ensure the application does not exceed the allowable power dissipation of the IC package. The recommended motor driver power dissipation versus temperature is depicted as follows:



FITIPOWER DCC CONTROL COPY

Package Specifications:

TDFN-10 Package (Unit: mm)

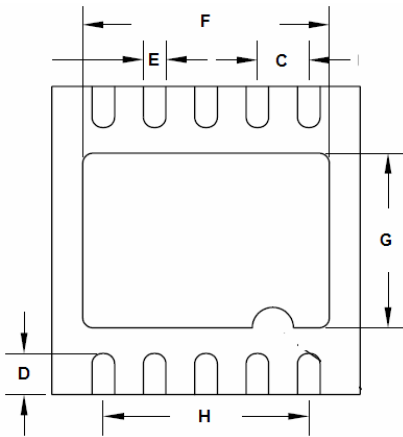
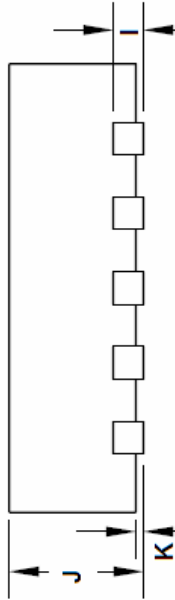
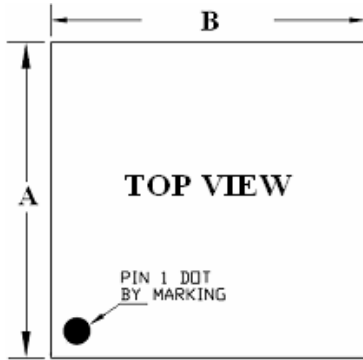

SYMBOLS UNIT	DIMENSION MILLIMETER		
	MIN.	NOM.	MAX.
A	2.95	3.00	3.05
B	2.95	3.00	3.05
C	0.50 BASIC		
D	0.35	0.40	0.45
E	0.17	0.22	0.27
F	2.35	2.40	2.45
G	1.65	1.70	1.75
H	2.00 REF		
I	0.203 REF		
J	0.70	0.75	0.80
K	0.00	0.02	0.05

Note 1 : Followed From JEDEC MO-012.

Life Support Policy

Fitipower's products are not authorized for use as critical components in life support devices or other medical systems.

FITIPOWER DCC
CONTROL COPY



Revision History

Revision	Content	Date
1.0	New Issue	2006-10-31
1.1	1, Add truth table waveform 2, Change the package specifications information.	2007-01-07
1.2	Add application note.	2007-07-18
1.3	Package type: TD (TDFN-10) => WD (TDFN10)	2007-11-29
1.4	Package standard change to Green mode product.	2008-2-28

FITIPOWER DCC
CONTROL COPY