

HIGH FREQUENCY PWM CONTROL IC SHORT CIRCUIT RESTART FUNCTION

GENERAL DESCRIPTION

The **FP5003**, a high performance monolithic IC, includes adjustable frequency oscillator and error amplifier for pulse modulation width (PWM) control, 1.0V precision voltage reference, under-voltage lockout circuit (UVLO), variable pulse width dead time control (DTC) circuit and programmable auto-restart timer for short circuit shutdown protection (SCSAR). Built-in totem-pole transistors pair to drive MOS directly at high frequency operation for high efficiency. It is very easy to design a dc-dc converter using a few external components, and typical application example is shown below:

FEATURES

- Reference Voltage Precision:2%
- Output source/sink current up to 100mA
- Totem-Pole output for MOS drive
- Wide operating voltage range:3.6~30V
- Variable dead-time control (DTC)
- Under voltage lockout protection function (UVLO)
- Short circuit shutdown protection / auto re-start function (SCSAR)
- Oscillator Frequency:Max.1.5MHz
- Package:SOP8/MSOP8/SOP8(EP)

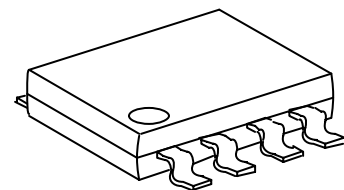

SOP8

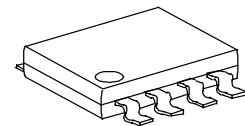

MSOP8

TYPICAL APPLICATION CIRCUIT

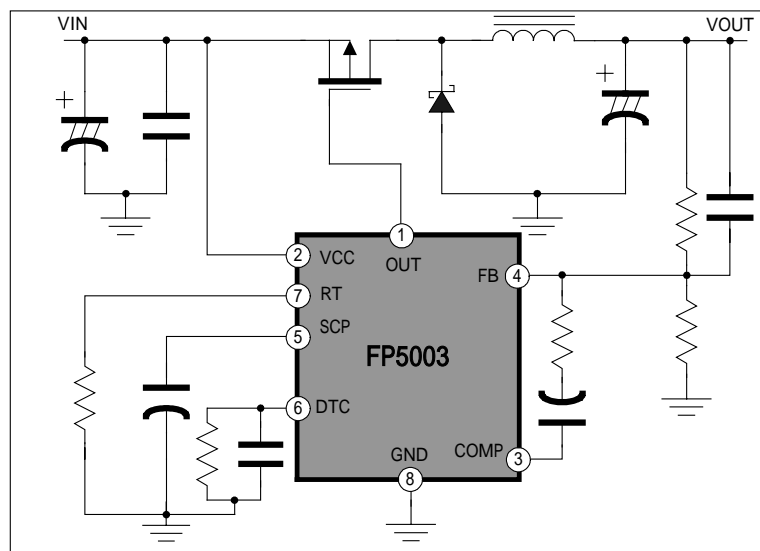

FUNCTIONAL BLOCK DIAGRAM

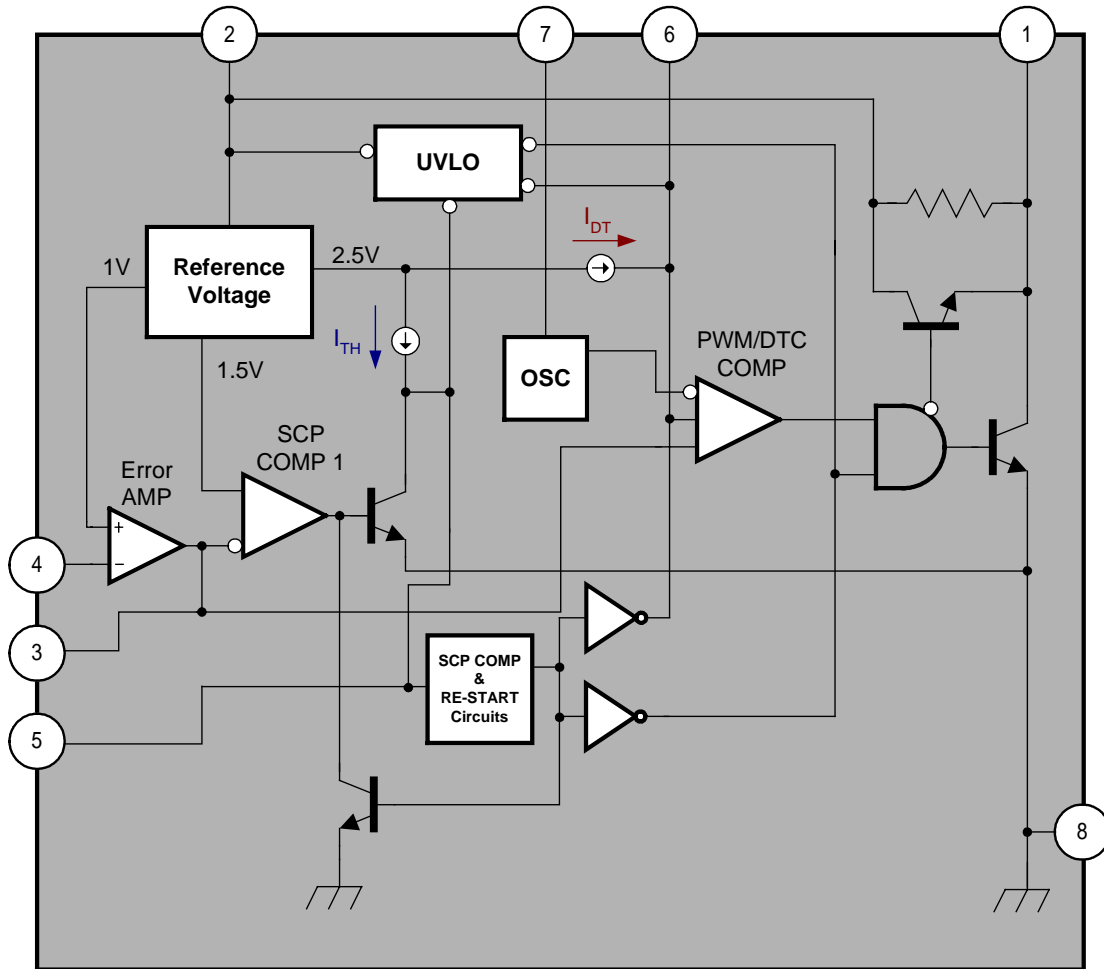

MARK VIEW

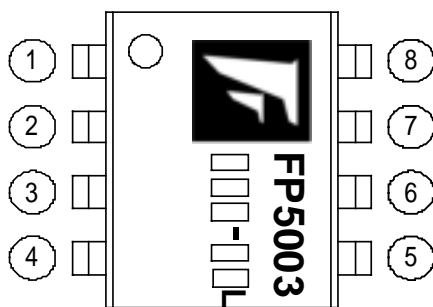

PIN DESCRIPTION

	NO.	STATUS	DESCRIPTION
OUT	1	O	Totem-pole Transistors Pair Output
VCC	2	P	IC Power Supply
COMP	3	O	Error Amplifier Feedback Output
FB	4	I	Error Amplifier Inverting Input
SCSAR	5	I	Short Circuit Protection Input
DTC	6	I	Dead-Time Control Input
RT	7	I	A resistance of Oscillator
GND	8	P	IC Ground

ORDER INFORMATION

Part Number	Op. Temperature	Package	Description
FP5003D-LF	-20 105	SOP8	Tube
FP5003DR-LF	-20 105	SOP8	Tape & Reel
FP5003T-LF	-20°C 105°C	MSOP8	Tube
FP5003TR-LF	-20°C 105°C	MSOP8	Tape & Reel
FP5003X-LF	-20°C ~ +105°C	SOP8-EXPOSED PAD	Tube
FP5003XR-LF	-20°C ~ +105°C	SOP8-EXPOSED PAD	Tape & Reel

IC DATE CODE DISTINGUISH

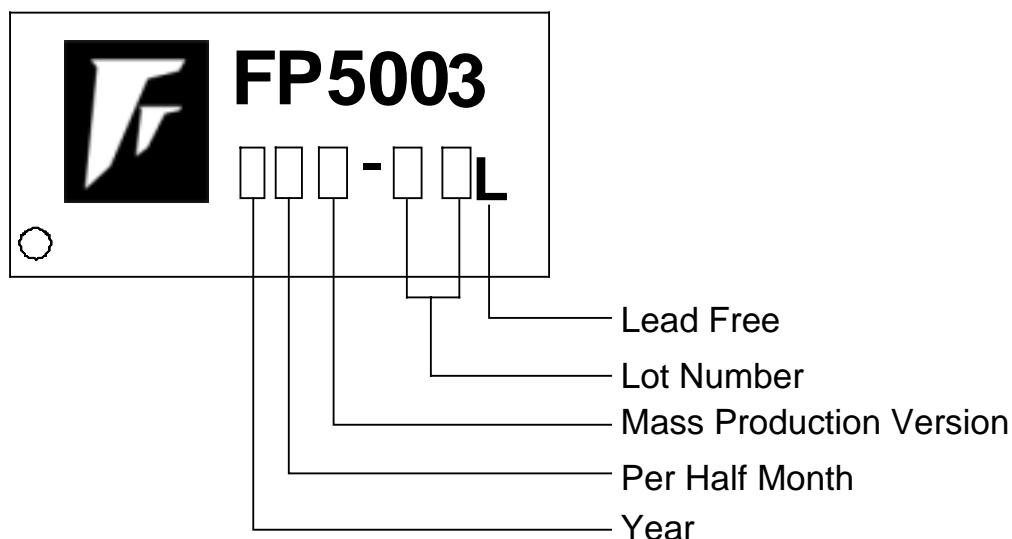

FOR EXAMPLE:

January A (Front Half Month), B (Last Half Month)

February C, D

March E, F -----And so on.

Lot Number is the last two numbers

For Example:

A3311C62

→ Lot Number

ABSOLUTE MAXIMUM RATINGS

Supply Voltage (Vcc) -----	+30V
Output Voltage (Vo) -----	+30V
Source/Sink Output Current (Io) -----	+/-150mA
Junction Temperature (T _j) -----	+150
Allowable dissipation	
SOP8 Ta +25 -----	570mW
MSOP8 Ta +25 -----	400mW
SOP8-EXPOSED PAD Ta +25 -----	600mW
Thermal Resistance	
SOP8	
T _{JA} -----	130 /W
T _{JC} -----	38.8 /W
MSOP8	
T _{JA} -----	260 /W
T _{JC} -----	60 /W
SOP8(EP)	
T _{JA} -----	120 /W
T _{JC} -----	38.8 /W
Operating Temperature Range -----	-20 +105
Storage Temperature Range -----	-65 +150
SOP8 Lead Temperature (soldering, 10 sec) -----	+260
MSOP8 Lead Temperature (soldering, 10 sec) -----	+260
SOP8(EP) Lead Temperature (soldering, 10 sec) -----	+260

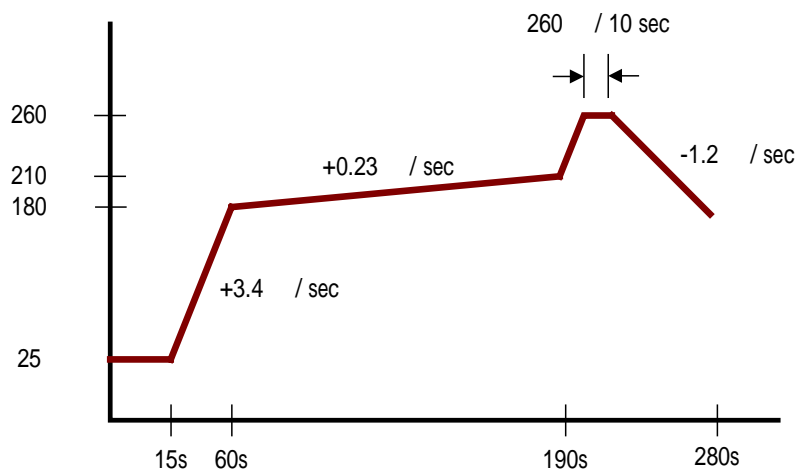
Lead Free Soldering Curve

DC ELECTRICAL CHARACTERISTICS

Recommended operating conditions: $V_{CC}=6V$ (unless otherwise noted)

All typical values are at $T_A=25$

Reference

PARAMETER	SYMBOL	TEST CONDITIONS	MIN	TYP	MAX	UNIT
Output voltage	V_{REF}	COMP connected FB	0.98	1	1.02	V
Input regulation	V_{REF}	$V_{CC}=3.6V$ to $30V$		2	12.5	mV
Output voltage change with temperature	V_{REF} / V_{REF}	$T_A=-20$ to 25	-10	-1	15	mV/V
		$T_A=25$ to 85	-10	-2	10	

Under voltage lockout

PARAMETER	SYMBOL	TEST CONDITIONS	MIN	TYP	MAX	UNIT
Upper threshold voltage	V_{UPPER}			3		V
Lower threshold voltage	V_{LOW}			2.8		V
Hysteresis	V_{HYS}		100	200		mV

Short-circuit protection

PARAMETER	SYMBOL	TEST CONDITIONS	MIN	TYP	MAX	UNIT
SCP standby voltage	V_{SB}	$V_{COMP} < 1.5V$		0.2		V
SCP threshold voltage	V_{TH}	$V_{COMP} > 1.5V$		0.7		V
SCP re-start charge current	I_{RSC}	$V_{COMP} > 1.5V$		20		μA
SCP re-start / hold time	T_{RS} / T_{HOLD}	$V_{COMP} > 1.5V$		1/32		Ratio
SCP comparator 1 threshold voltage	$V_{COMP(TH)}$			1.5		V

Note1: Function Diagram figure 17

Oscillator

PARAMETER	SYMBOL	TEST CONDITIONS	MIN	TYP	MAX	UNIT
Frequency	f	$R_i=100K$		260		KHz
Standard deviation of frequency	f			15		KHz
Frequency change with voltage	f / V	$V_{CC}=3.6V$ to $30V$		1		KHz
Frequency change with temperature	f / T	$T_A=-20$ to 25		± 1		%
		$T_A=25$ to 105		± 1		%
Voltage at RT	V_{RT}			1		V

DC ELECTRICAL CHARACTERISTICS (Cont.)
Dead-time control

PARAMETER	SYMBOL	TEST CONDITIONS	MIN	TYP	MAX	UNIT
Output (source) current	I_{SOURCE}	$V_{(DT)}=1.5V$	$0.9 \times I_{RT}$		$1.2 \times I_{RT}$	V
Input threshold voltage	V_{TH}	Duty cycle=0%	0.5	0.7		V
		Duty cycle=100%		1.3	1.5	

Error amplifier

PARAMETER	SYMBOL	TEST CONDITIONS	MIN	TYP	MAX	UNIT
Input voltage	V_{IN}	$V_{CC}=3.6V$ to $30V$	0		1.5	V
Input bias current	V_{BIAS}			-160	-500	nA
Output voltage swing	Positive	V_{POS}	1.5	2.3		V
	Negative	V_{NEG}		0.3	0.4	V
Open-loop voltage amplification	A_{VO}			80		dB
Unity-gain bandwidth	BW_U			1.5		MHz
Output (sink) current	I_{SINK}	$V_{I(FB)}=1.2V, COMP=1V$	600	800		μA
Output (source) current	I_{SOURCE}	$V_{I(FB)}=0.8V, COMP=1V$	-100	-150		μA

Output

PARAMETER	SYMBOL	TEST CONDITIONS	MIN	TYP	MAX	UNIT
Output low voltage	V_{OL}	$I_o=100mA$		1.7		V
Output high voltage	V_{OH}	$I_o=100mA$		4.4		V

Total device

PARAMETER	SYMBOL	TEST CONDITIONS	MIN	TYP	MAX	UNIT
Standby supply current	Off state	$I_{STANDBY}$		3.5	4.0	mA
Average supply current	I_{AVE}	$R_T=100K$		3.8	5	mA

TYPICAL CHARACTERISTICS

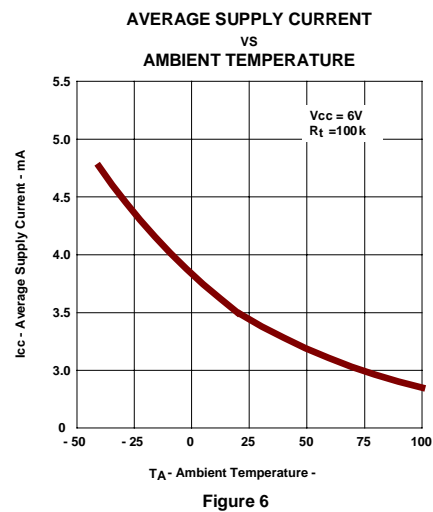
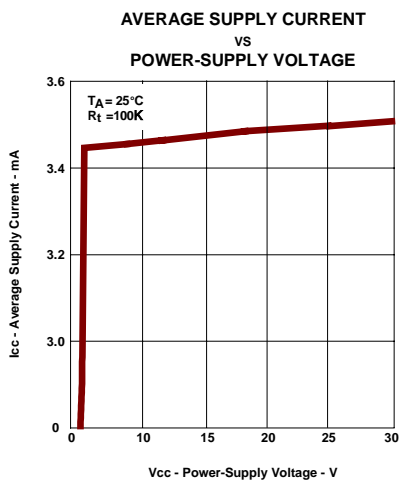
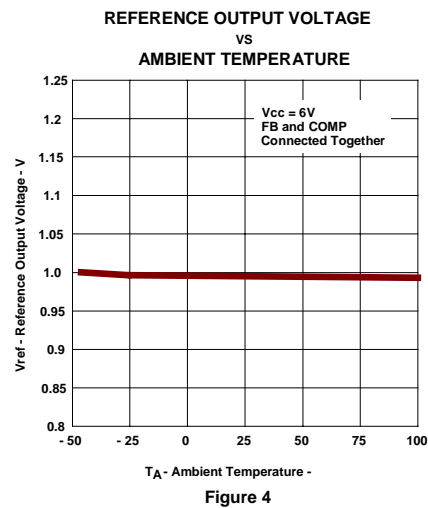
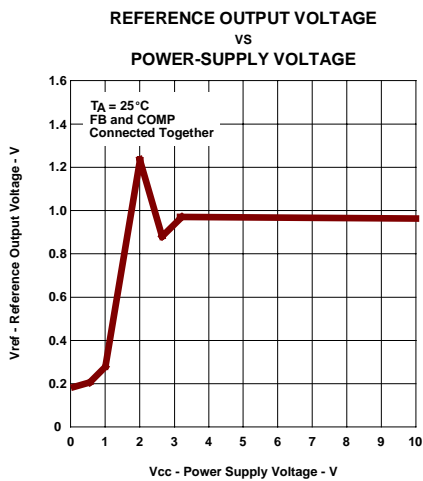
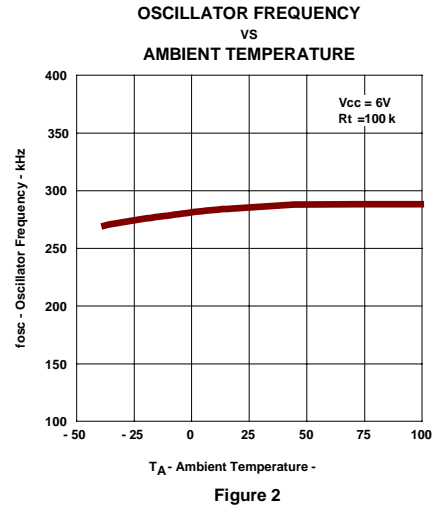
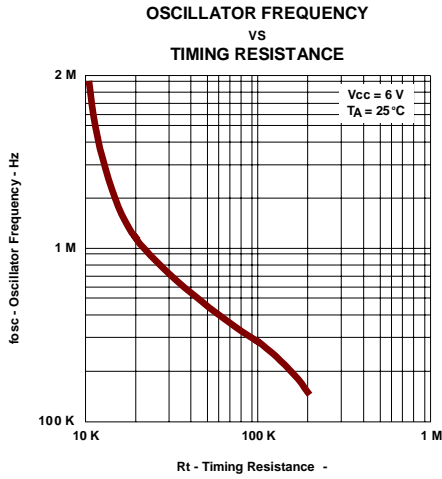

TYPICAL CHARACTERISTICS(Cont.)

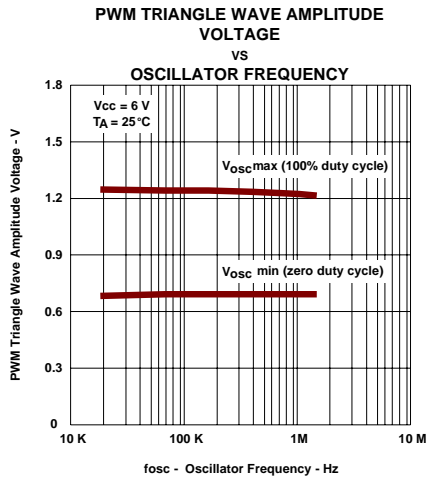

Figure 7

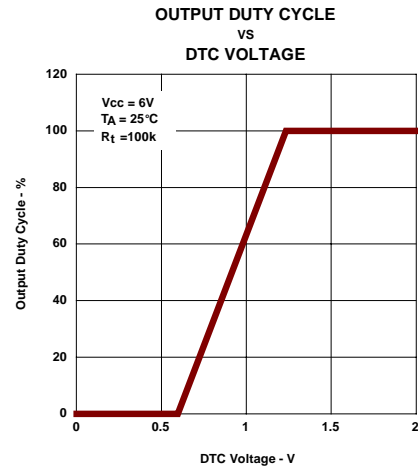

Figure 8

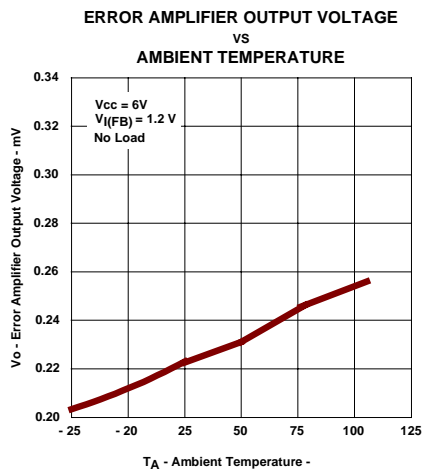

Figure 9

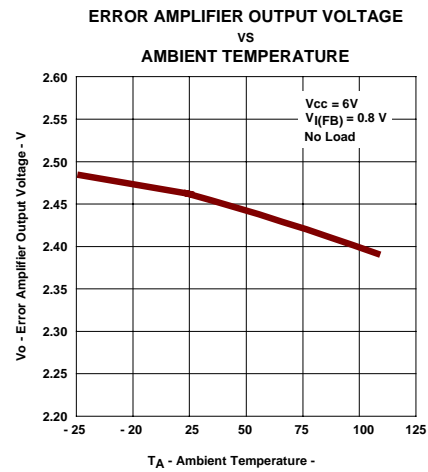

Figure 10

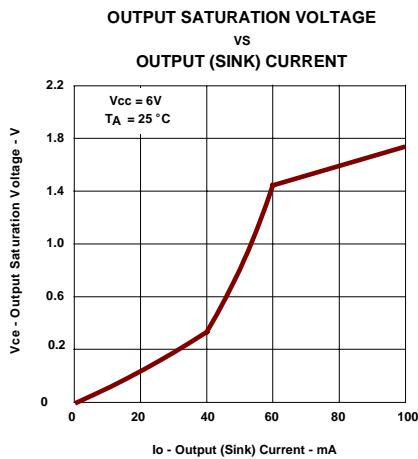

Figure 11

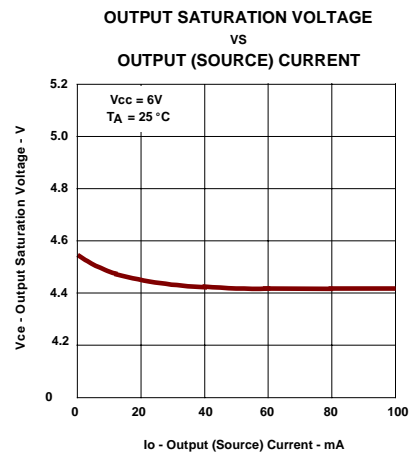

Figure 12

DETAILED DESCRIPTION

Voltage reference

A 2.5V reference regulator supplies **FP5003** internal circuits and uses the resistive dividers to provide a 1.0V precision reference voltage on the non-inverting terminal of error amplifier and SCP comparator 1.0V threshold voltage.

Error amplifier

The error amplifier compares the feedback voltage from dc-dc converter output to the 1.0V reference and generates the error signal for the PWM comparator. The relation between VI(FB) and **FP5003** error amplifier pins are shown below (see Figure 13).

$$VI(FB) = \left(1 + \frac{R1}{R2}\right) * V_{REF}$$

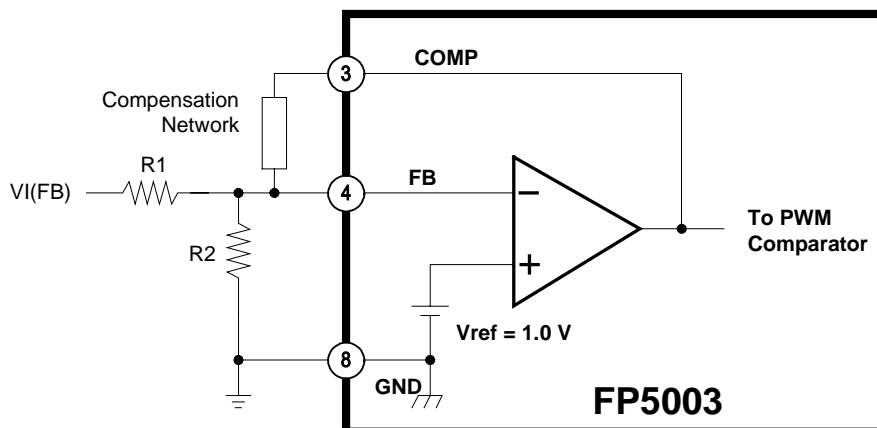

Figure 13. Error Amplifier with Converter Feedback Resistors

Note:

It is necessary to check the converter total open loop gain and phase shift from Bode plot before compensation network adjustment. Finally, let the system works stability.

Oscillator/PWM Comparator

The oscillator frequency (f_{osc}) can be decided from 20KHz to 1.5MHz by the resistor connected to R_T pin. The oscillator can be determined by the graph shown in Figure 1.

The internal oscillator output is a triangular waveform and its minimum voltage level is approximately 0.7V and maximum level approximately 1.3V (see Figure 14). The PWM comparator compares the triangular waveform with the signals from output voltage of error-amplifier and the DTC voltage, the PWM comparator output controls the output stage of totem-pole transistors pair off or on whenever the triangular wave is greater than the both input signals or less.

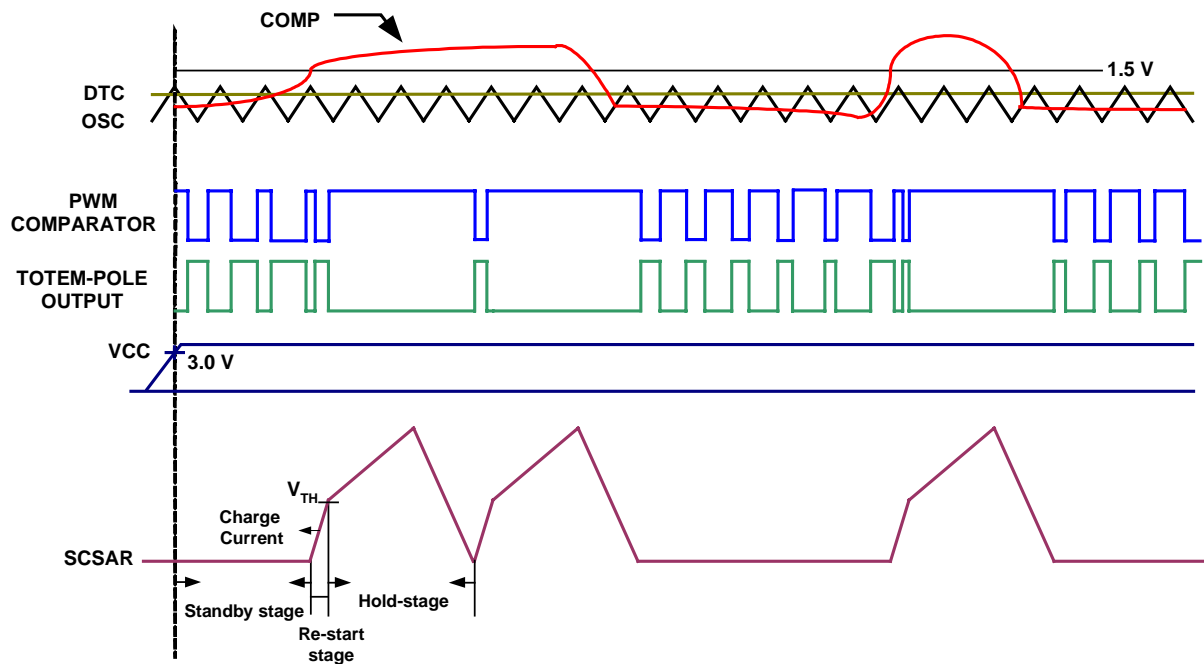

Figure 14. PWM Timing Diagram

Dead-time control (DTC)

DTC main function is a limitation of PWM duty cycle less than 100%. The source current of R_T is same as dead-time current I_{DT} at DTC pin. There is resistor R_{DT} connecting between DTC and GND and generating a bias voltage V_{DT} that compares with the output waveform of oscillator in the PWM comparator. The PWM duty cycle begins 0% when V_{DT} sets at 0.7V or less, and then V_{DT} sets at 1.3V or greater and PWM duty cycle reaches 100%. Engineer can choose a resistor R_{DT} for a specific limitation of PWM duty cycle D .

According to the follow formula, we can choose a R_{DT} for a maximum duty cycle.

$$R_{DT} = (R_T + 1250) * (0.6 * D + 0.7)$$

For example:

R_T is 33K for oscillator frequency, and we assume the maximum duty cycle is 75%.

$$R_{DT} = (33K + 1250) * (0.6 * 0.75 + 0.7) = 39.38K$$

When using a resistor R_{DT} is 39.38K, the limitation of PWM duty cycle is 75%.

A capacitor (C_{DT}), connecting with the resistor R_{DT} as shown in Figure 15, is a soft-start function when power on. The soft-start time formula is shown as below:

$$V_{DT} \approx I_{DT} * R_{DT} \left(1 - e^{-\frac{t}{R_{DT} C_{DT}}} \right)$$

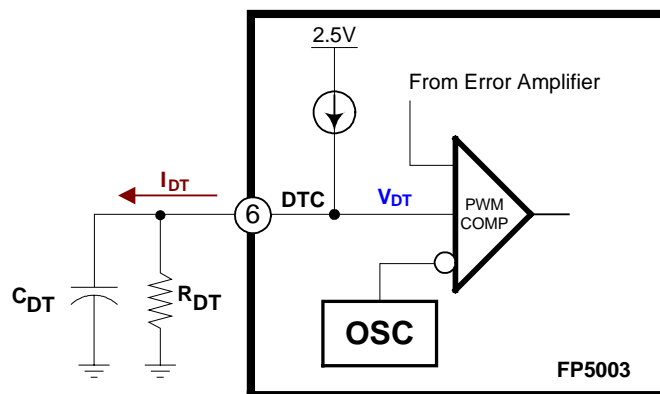

Figure 15. Soft-Start Circuit

Note:

C_{DT} is discharged by internal circuit every time when UVLO or SCP becomes active.

Under voltage lock-out (UVLO) protection

When the power supply turns off, the output of **FP5003** also turns off and resets the SCP latch whenever the supply voltage drops under the UVLO off threshold voltage. It is a simple protection function when the supply voltage can not maintain at a stable operating condition. The UVLO hysteresis voltage avoids an internal false trigger whenever power noise or spike.

Short-circuit shutdown and auto re-start protection (SCSAR)

FP5003 includes short-circuit shutdown and auto re-start protection function (see Figure 16), which turns the Power MOS off to prevent damage when the converter output is over loading or short circuit.

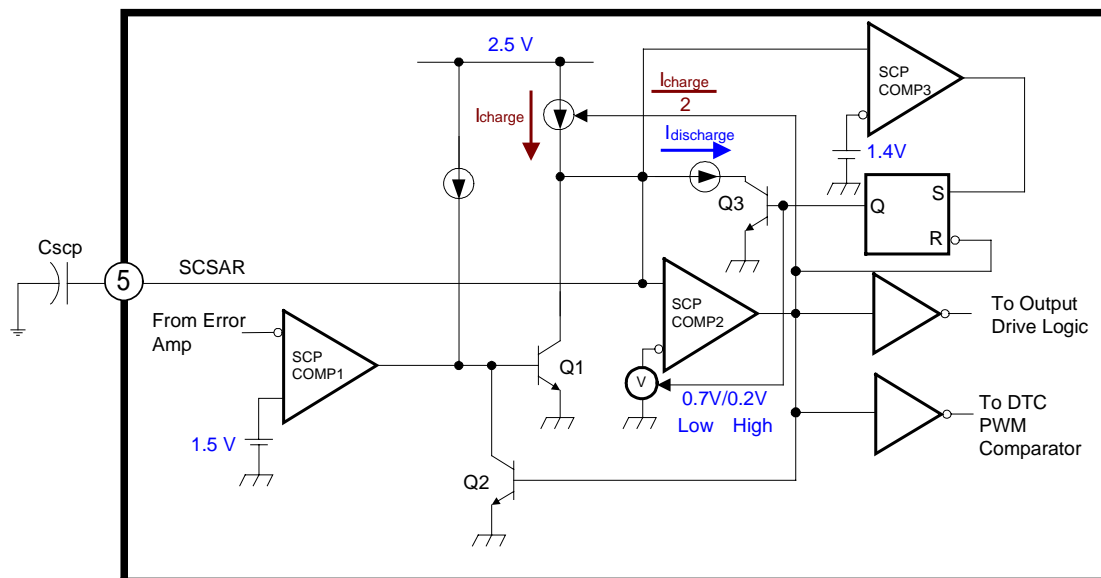

Figure 16. SCSAR Protection Circuit

Generally, error amplifier output voltage is lower than 1.5V, and SCP comparator 1 output keeps a high state and Q1 is turn-on, C_{SCP} cannot be charged. When short circuit occurs, the COMP pin of error-amplifier would rise more than 1.5V, SCP comparator 1 output changes to low state and C_{SCP} is charged by I_{CHARGE} current. The SC function of **FP5003** is release because short circuit is removed before Q2 active and SCP comparator 2 is latch. When C_{SCP} is charged until a 0.7V threshold voltage and SCP comparator 2 output changes to high state and Q2 is turn-on to keep Q1 off in latch mode. Meanwhile, the source current of C_{SCP} would change half of original current for the first shutdown phase, **FP5003** output is turn-off and DTC pin is pull-low. When C_{SCP} voltage is greater than 1.4V of SCP comparator 3, the output of S-R Latch would turn on Q3 and change SCP comparator 2 from 0.7V to 0.2V, when SCP comparator 3 is active, C_{SCP} is discharged until SCP comparator 2 is release the latch state,

output of **FP5003** is active and DTC pin is working in soft-start state or limitation of duty cycle. C_{SCP} discharging time from 1.4V to 0.2V is the second shutdown phase which finishes and **FP5003** would be release shutdown state and re-start the normal operation. Figure 17 is a relation description about SCSAR pin and the other pins of **FP5003**.

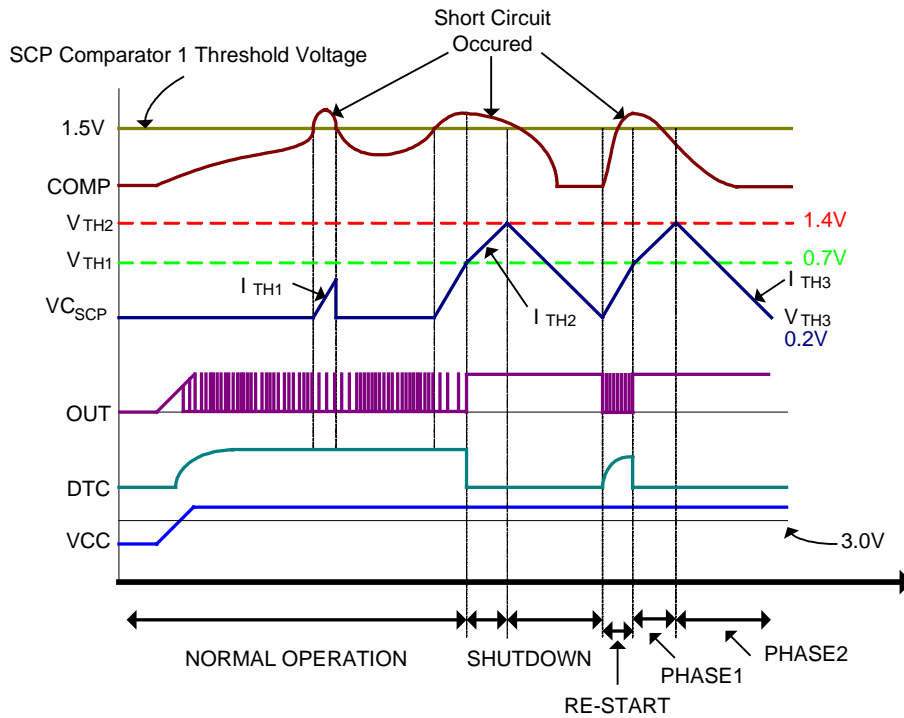

Figure 17. Shutdown and Re-start waveform

The formulas are shown below for shutdown and re-start time calculation:

AUTO RE-START time equation:

$$t_{RE-START} = \frac{V_{TH1} * C_{SCP}}{I_{TH1}}$$

SHUTDOWN time equation:

$$t_{SHUTDOWN} = t_{PHASE1} + t_{PHASE2} = \frac{(V_{TH2} - V_{TH1}) * C_{SCP}}{I_{TH2}} + \frac{(V_{TH2} - V_{TH3}) * C_{SCP}}{I_{TH3}}$$

Output transistors

The output of the **FP5003** is a totem-pole transistor pair, which supplies source and sink current capacity for driving the external MOSFET directly, a basic drive method is shown as figure 18.

When PWM operation frequency is different, the both of on and off time of MOSFET also are different.

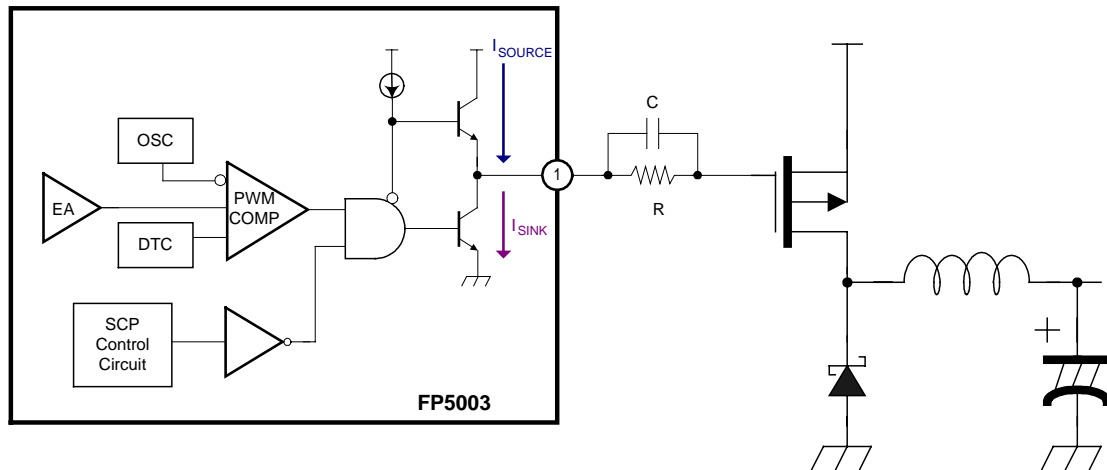

Figure 18. MOSFET Output Driving Circuit

Note:

It is very important to choose a suitable MOSFET for high frequency operation. The larger capacitor between gate and source of MOSFET has more switching loss under the same condition as high frequency operation, supply voltage and driving current.

APPLICATION NOTE

Application Example: $V_{IN} = DC5.0V \sim DC24.0V$

$V_{OUT} = DC3.3V, I_{OUT} = 2.0A$

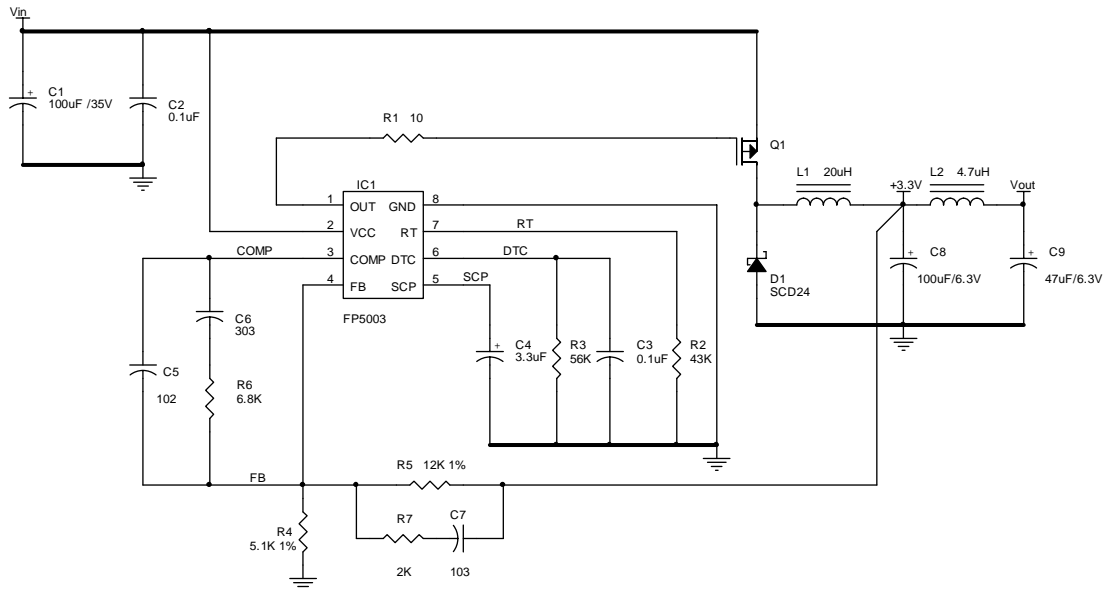

Note:

This is a basic circuit of **FP5003** example, C4 is a short circuit and re-start timing capacitor (C_{SCP}), R3 and C3 use for soft-start dead time control ($R_{DTC} * C_{DTC}$), R2 uses for adjustable oscillator frequency (R_T), R5 and R4 are feedback bias resistor for V_{OUT} , C5-R6-C6 are compensation network for total open loop stability.

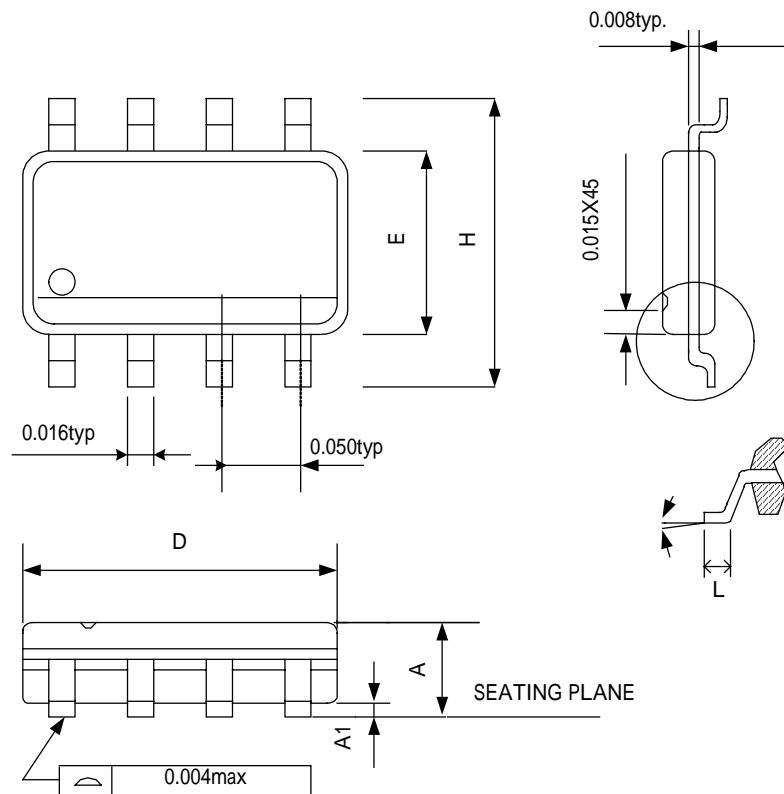
PACKAGE OUTLINE
SOP 8

SYMBOLS	MIN	MAX
A	1.346	1.752
A1	0.101	0.254
D	4.800	4.978
E	3.810	3.987
H	5.791	6.197
L	0.406	1.270
°	0	8

UNIT:MM

NOTE:

- JEDEC OUTLINE:MS-012 AA
- DIMENSIONS "D" DOES NOT INCLUDE MOLD FLASH,PROTRUSIONS OR GATE BURRS.MOLD FLASH,PROTRUSIONS AND GATE BURRS SHALL NOT EXCEED .15mm (.0.06in) PER SIDE
- DIMENSIONS "E" DOES NOT INCLUDE INTER-LEAD FLASH,OR PROTRUSIONS. INTER-LEAD FLASH AND PROTRUSIONS SHALL NOT EXCEED .25mm (.0.10in) PER SIDE.

MSOP8

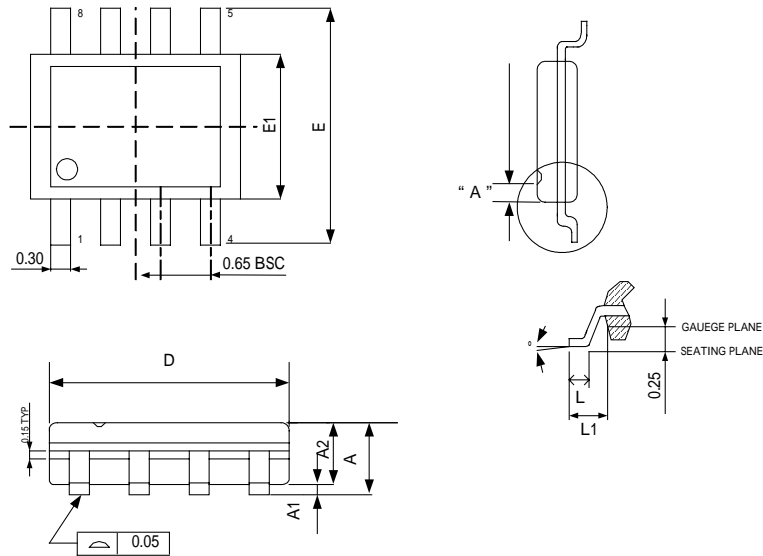

SYMBOLS	MIN	MAX
A	-	1.10
A1	0.00	0.15
A2	0.75	0.95
D	3.00 BSC	
E	4.90 BSC	
E1	3.00 BSC	
L	0.40	0.80
L1	0.95 REF	
°	0	8

UNIT:MM

NOTE:

1. JEDEC OUTLINE:MO-187 AA
2. DIMENSIONS "D" DOES NOT INCLUDE MOLD FLASH,PROTRUSIONS OR GATE BURRS.MOLD FLASH,PROTRUSIONS AND GATE BURRS SHALL NOT EXCEED 0.15 PER SIDE
3. DIMENSIONS "E1" DOES NOT INCLUDE INTERLEAD FLASH,OR PROTRUSIONS. INTERLEAD FLASH OR PROTRUSIONS SHALL NOT EXCEED 0.25 PER SIDE.
4. DIMENSIONS "0.22" DOES NOT INCLUDE DAMBAR PROTRUSIONS.ALLOWABLE DAMBAR PROTRUSIONS SHALL BE 0.08 MM TOTAL IN EXCESS OF THE '0.22' DIMENSION AT MAXIMUM MATERIAL CONDITION.DAMBAR CANNOT BE LOCATED ON THE LOWER RADIUS OF THE FOOT.MINIMIM SPAC BETWEEN PROTRUSION AND ADJACENT LEAD IS 0.07MM.
5. DIMENSIONS "D" AND 'E1' TO BE DETERMINED AT DATUM PLANE H

SOP8-EXPOSED PAD

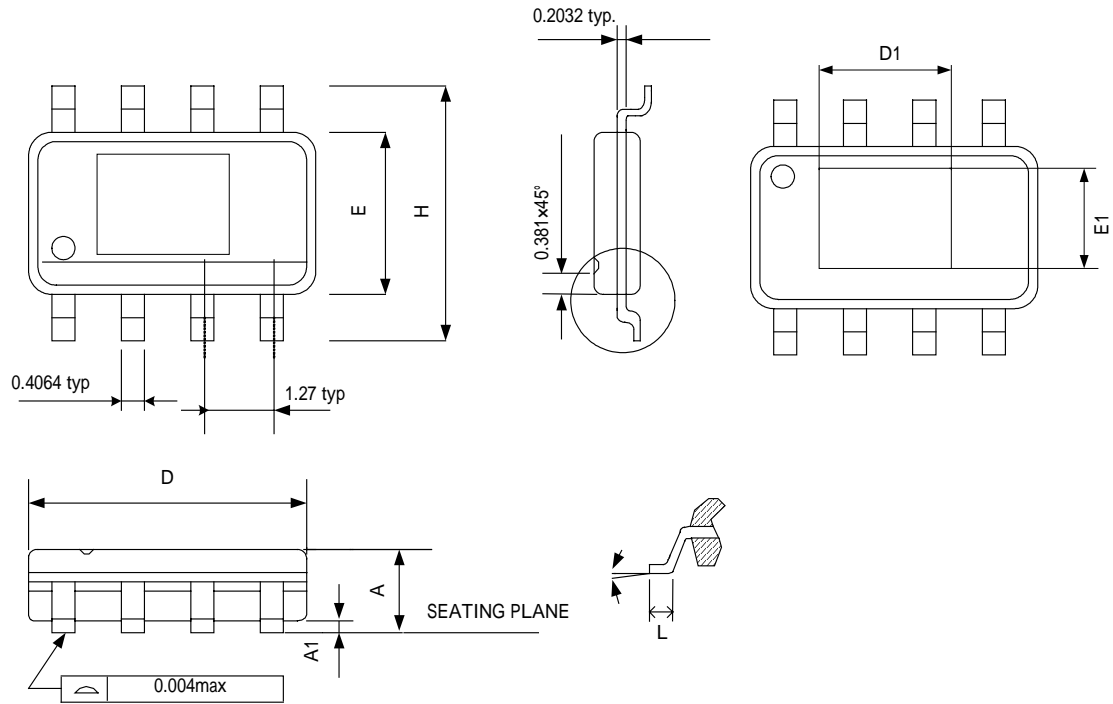

SYMBOLS	MIN	MAX
A	1.346	1.752
A1	0.101	0.254
D	4.800	4.978
E	3.810	3.987
H	5.791	6.197
L	0.406	1.270
°	0	8

UNIT:MM

THERMALLY ENHANCED DIMENSIONS

PAD SIZE	E1	D1
A	2.057 REF	2.057 REF
A1	2.184 REF	2.971 REF

UNIT:MM

NOTE:

1. JEDEC OUTLINE:N/A
2. DIMENSIONS "D" DOES NOT INCLUDE MOLD FLASH,PROTRUSIONS OR GATE BURRS.MOLD FLASH,PROTRUSIONS AND GATE BURRS SHALL NOT EXCEED .15mm (.006in) PER SIDE
3. DIMENSIONS "E" DOES NOT INCLUDE INTER-LEAD FLASH,OR PROTRUSIONS. INTER-LEAD

BOX DIMENSION

TUBE INSIDE BOX AND CARTON

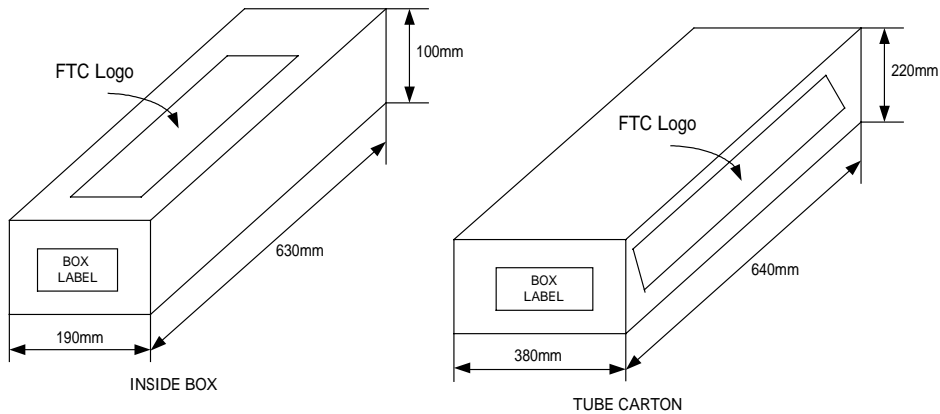

TAPE & REEL INSIDE BOX AND CARTON

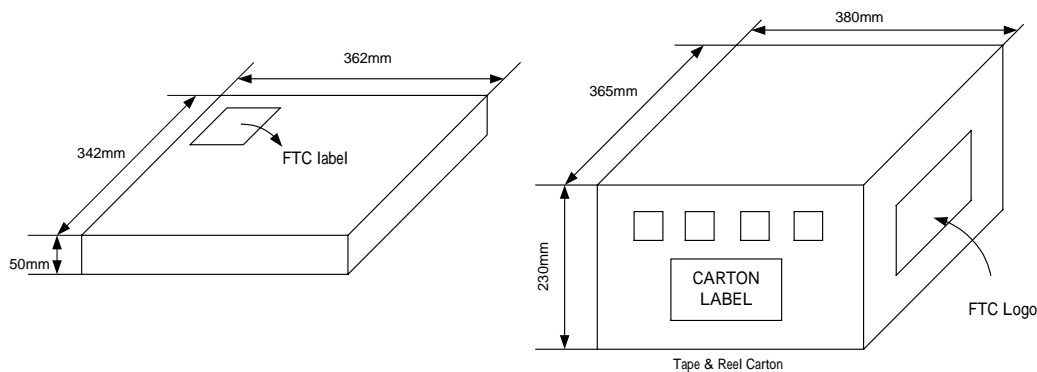

PACKING QUANTITY SPECIFICATIONS

SOP 8 / SOP8(EP)	MSOP8	SOP 8 / SOP8(EP)	MSOP8
100 EA/TUBE	80 EA/TUBE	2500 EA / REEL	
100 TUBES / INSIDE BOX		4 INSIDE BOXES / CARTON	
4 INSIDE BOXES / CARTON			

LABEL SPECIFICATIONS

TAPPING & REEL

Feeling Technology Corp. Product FP5003DR-LF Lot No A3311C62 D/C 4Xx-XXL Q'ty	無鉛 Lead Free
---	-------------------------------

CARTON

Feeling Technology Corp.	
Product Type: FP5003DR-LF	
Lot No: A3311C62	
Date Code: 4Xx-XXL	
Package Type: SOP-8L	
Marking Type: Laser	無鉛 Lead Free
Total Q'ty: 10,000	

SOP8 / SOP8 (EP) CARRIER TAPE DIMENSIONS

APPLICATION	W	P	E	F	D	D ₁
SOP8 / SOP8 (EP)	12.0 ^{+0.3} _{-0.1}	8.0±0.1	1.75±0.1	5.5±0.1	1.55±0.1	1.5 ^{+0.25}

APPLICATION	P ₀	P ₁	A ₀	B ₀	K ₀	t
SOP8 / SOP8 (EP)	4.0±0.1	2.0±0.1	6.4±0.1	5.20±0.1	2.1±0.10	0.30±0.013

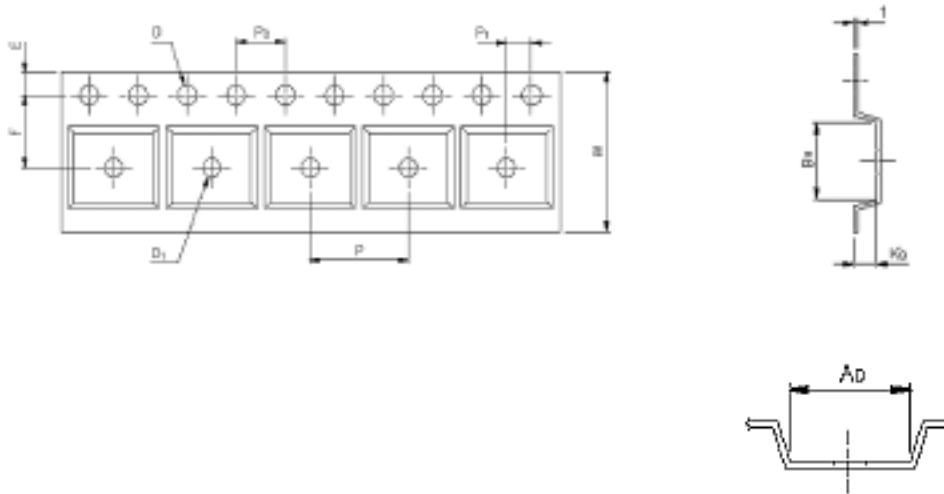

REEL DIMENSIONS

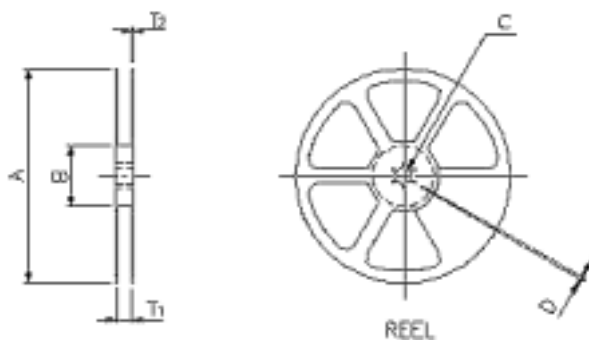

APPLICATION	MATERIAL	A	B	C	D	T ₁	T ₂
SOP8 / SOP8(EP)	PLASTIC REEL	330±0.1	62±1.5	12.75±0.15	2±0.6	12.4±0.2	2.0±0.2

MSOP8 CARRIER TAPE DIMENSIONS

APPLICATION	W	P	E	F	D	D ₁
MSOP8	12.0±3	8.0	1.75±1.0	5.5±0.5	1.5 ^{+0.1}	1.50

APPLICATION	P ₀	P ₁	A _D	B ₀	K ₀	t
MSOP8	4.0±0.1	2.0±0.5	4.20	3.30	1.20	0.30±0.5

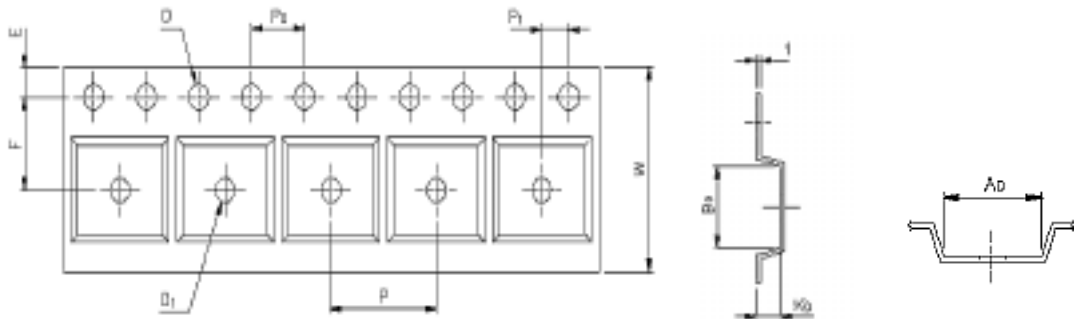

REEL DIMENSIONS

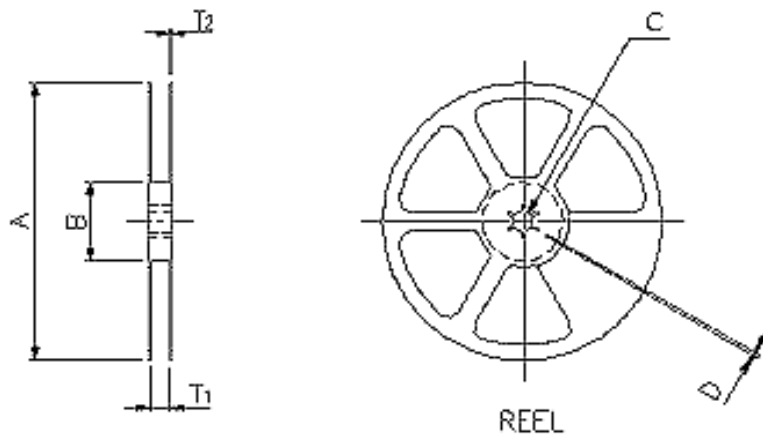

APPLICATION	MATERIAL	A	B	C	D	T ₁	T ₂
MSOP8	PLASTIC REEL	330±1	62±1.5	12.75 ^{+0.15}	2±0.15	12.4 ^{+0.2}	16.8 ^{-0.4}