

DUAL OPERATIONAL AMPLIFIER AND REFERENCE REGULATOR

GENERAL DESCRIPTION

The **FP103**, a 1-chip composed of one independent op-amp (OPA2) and another op-amp (OPA1) with a 2.5V precision voltage reference on non-inverting input, applied to offer space and low cost in many applications such as the secondary feedback control of power supply, DC/DC converter or adaptor.

Using few external components, **FP103**, a high performance integrated IC, is designed for a feedback circuit. The circuit diagram of the typical application example is as below.

FEATURES

- Fixed Reference Voltage: 2.5V
- Reference Voltage Precision: 1%
- Output sink current up to 100mA
- Low quiescent supply current
- Wide operating voltage range: 3~32V(+/-16V)
- Low input offset voltage
- Unit gain bandwidth: 0.9MHz
- Package: PDIP8/SOP8

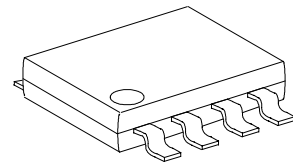

SOP8

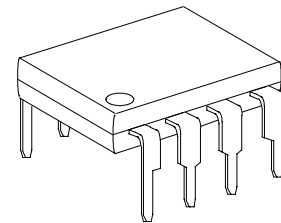

PDIP8

TYPICAL APPLICATION CIRCUIT

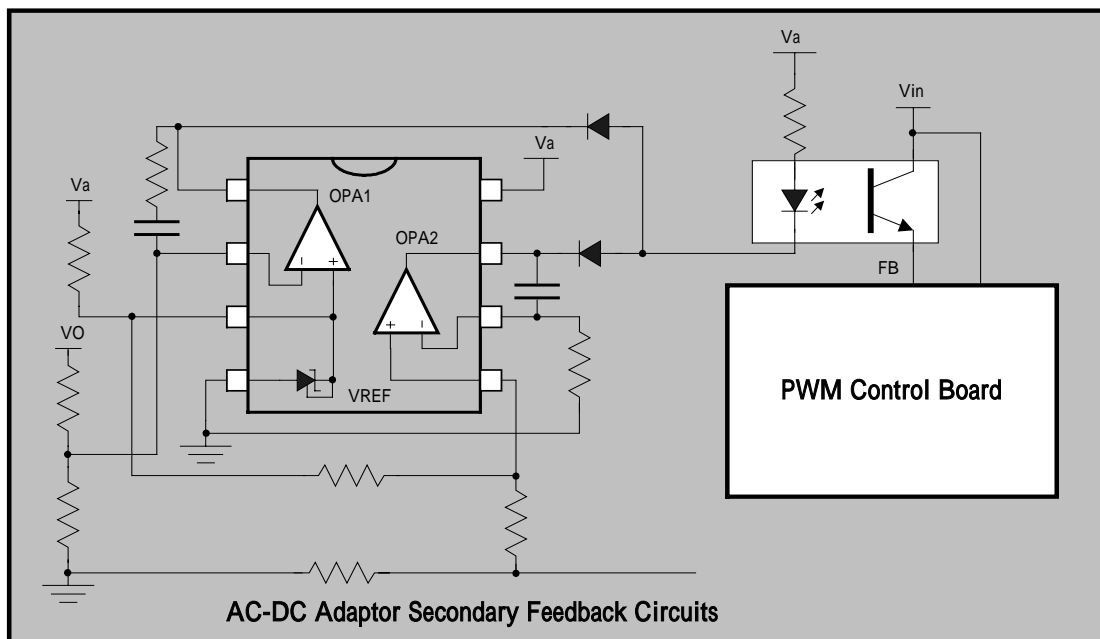

FUNCTIONAL BLOCK DIAGRAM

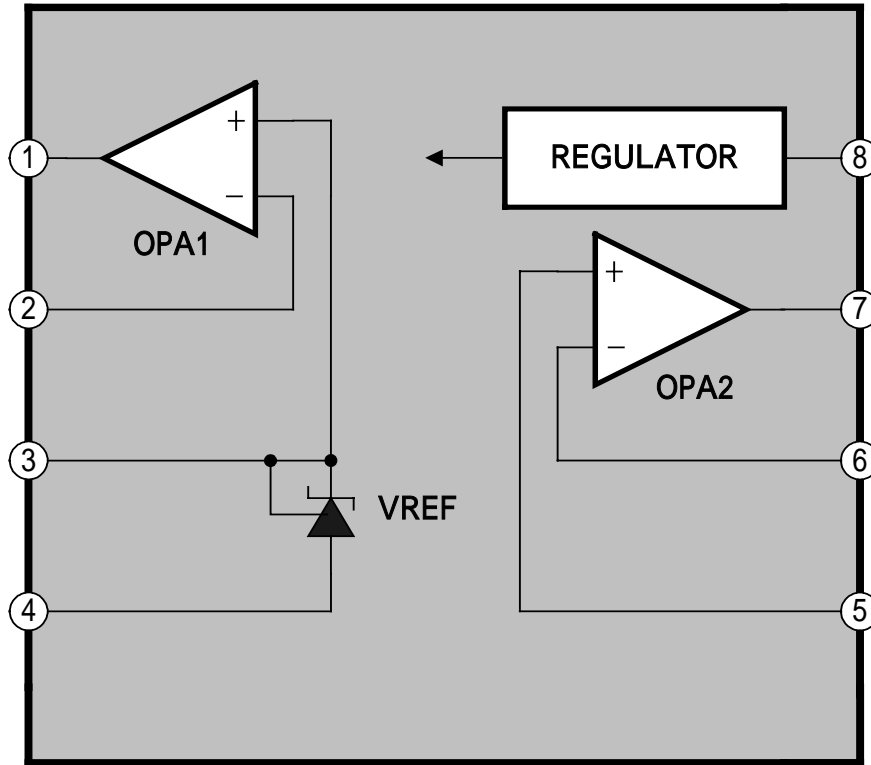

MARK VIEW

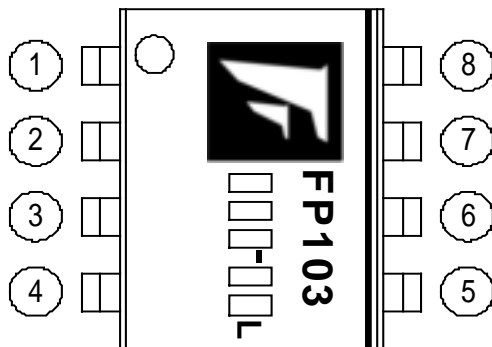

PIN DESCRIPTION

NAME	NO.	STATUS	DESCRIPTION
VO1	1	O	OPA1 Output
VI1	2	I	OPA1 Inverting Input
VNI1	3	I	OPA1 Non-inverting Input
VEE	4	P	IC Ground or Negative Supply Voltage
VNI2	5	I	OPA2 Non-inverting Input
VI2	6	I	OPA2 Inverting Input
VO2	7	O	OPA2 Output
VCC	8	P	Positive Supply Voltage

ORDER INFORMATION

Part Number	Operating Temperature	Package	Description
FP103P-LF	-20°C 85	PDIP8	Tube
FP103D-LF	-20°C 85	SOP8	Tube
FP103DR-LF	-20°C 85	SOP8	Tape & Reel

IC DATE CODE DISTINGUISH

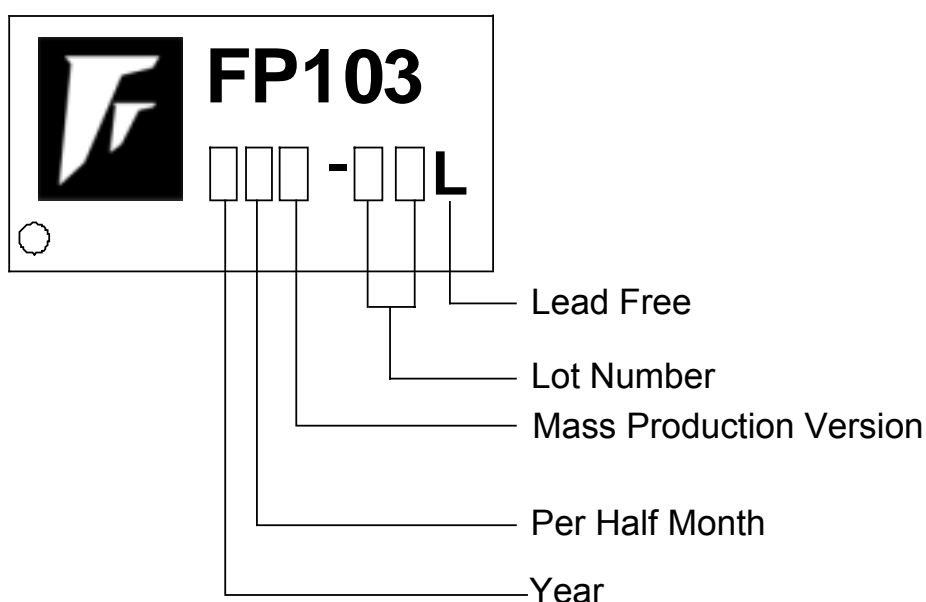

FOR EXAMPLE:

January A (Front Half Month), B (Last Half Month)
 February C, D
 March E, F -----And so on

Lot Number is the last two numbers

For Example:

A3311C62
 ↳ Lot Number

ABSOLUTE MAXIMUM RATINGS

Supply Voltage (V _{cc})	-----	+ 3.6 V
Differential Input Voltage (V _{id})	-----	+ 3.6 V
Input Voltage (V _i)	-----	-0.3 ~+36V
Maximum Junction Temperature (T _j)	-----	150
Thermal Resistance Junction to Ambient (SOP package)	-----	175 μ W
(PDIP package)	-----	100 μ W
Power Dissipation (SOP8 package)		
Ta=25	-----	650mW
Ta=70	-----	550mW
Operating Temperature Range (T _{min} ~T _{max} .)	-----	-20 85
Storage Temperature Range	-----	- 65 150
SOP8 Lead Temperature (soldering, 10 sec)	-----	+260
PDIP8 Lead Temperature (soldering, 20 sec)	-----	+260

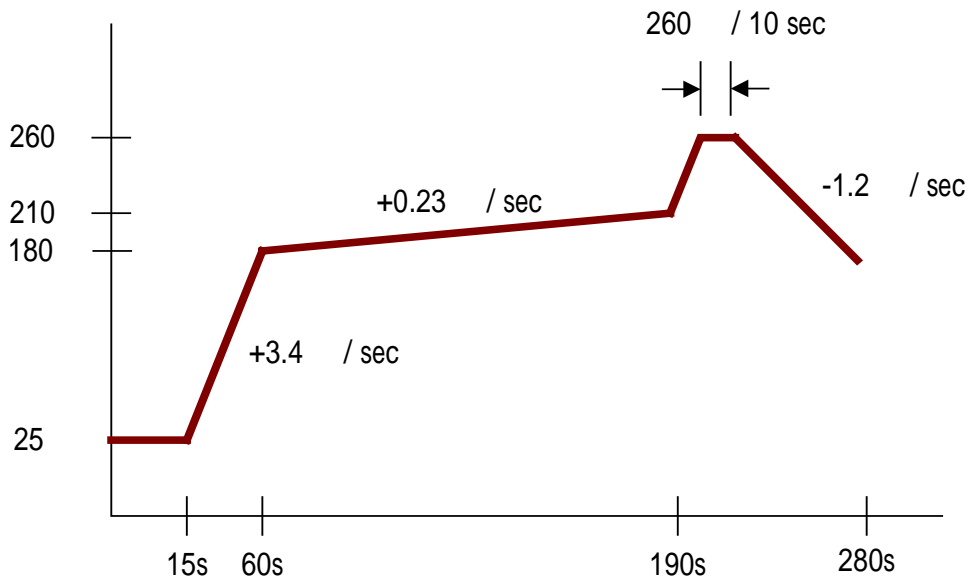

IR-REFLOW

DC ELECTRICAL CHARACTERISTICS

Operating Amplifier1

PARAMETER	SYMBOL	TEST CONDITIONS	MIN	TYP	MAX	UNIT
Input Offset Voltage	V_{io}	FP103, $T_{amb}=25$ $T_{min} \leq T_{amb} \leq T_{max}$.		1	4 5	mV
Input Offset Voltage Drift	DV_{io}	$T_{amb}=25$		7		$\mu V/$
Input Bias Current (negative input)	I_{ib}	$T_{amb}=25$ $T_{min} \leq T_{amb} \leq T_{max}$		20		nA
Large Signal Voltage Gain	A_{vd}	$V_{icm}=0V$ $V_{CC}=15V, R_L=2K$		100		V/mV
Supply Voltage Rejection Ratio	SVR	$V_{icm}=0V$ $V_{CC}=5V$ to 30V	65	100		dB
Output Current Source	I_{source}	$V_{CC}=+15V$ $V_O=2V, V_{id}=+1V$	30	50		mA
Short Circuit to Ground	I_o	$V_{CC}=+15V$		50	70	mA
Output Current Sink	I_{sink}	$V_{id}=-1V$ $V_{CC}=+15V, V_O=2V$	8	10		mA
High Level Output Voltage	V_{OH}	$V_{CC}^+=30V$ $T_{amb}=25$, $R_L=10K$ $T_{min} \leq T_{amb} \leq T_{max}$	27 27	28		V
Low Level Output Voltage	V_{OL}	$R_L=10K$ $T_{min} \leq T_{amb} \leq T_{max}$		3	20 20	mV
Slew Rate at Unity Gain	SR	$V_i=0.5$ to 2V, $V_{CC}=15V$ $R_L=2K, C_L=100pF$ Unity Gain	0.2	0.4		V/ μS
Gain Bandwidth Product	GBP	$V_{CC}=30V, R_L=2K$ $C_L=100pF, f=100kHz,$ $V_{in}=10$ mV	0.5	0.9		MHz
Total Harmonic Distortion	THD	$f=1kHz, A_V=20dB$ $R_L=2K, V_{CC}=30V$ $C_L=100pF, V_O=2V_{PP}$		0.02		%

DC ELECTRICAL CHARACTERISTICS (Cont.)

Operating Amplifier2

PARAMETER	SYMBOL	TEST CONDITIONS	MIN	TYP	MAX	UNIT
Input Offset Voltage	V_{io}	FP103, $T_{amb}=25$ $T_{min} \leq T_{amb} \leq T_{max}$.		1	4 5	mV
Input Offset Voltage Drift	DV_{io}	$T_{amb}=25$		7		$\mu V/$
Input Offset Current	I_{io}	$T_{amb}=25$ $T_{min} \leq T_{amb} \leq T_{max}$		2	30 50	nA
Input Bias Current	I_{ib}	$T_{amb}=25$ $T_{min} \leq T_{amb} \leq T_{max}$		20	150 200	nA
Large Signal Voltage Gain	A_{vd}	$V_{CC}=15V, R_L=2K,$ $V_O=1.4V$ to $11.4V$ $T_{min} \leq T_{amb} \leq T_{max}$	50 25	100		V/mV
Supply Voltage Rejection Ratio	SVR	$V_{CC}=5V$ to $30V$	65	100		dB
Input Common Mode Voltage Range	V_{icm}	$V_{CC}=+30V$ $T_{min} \leq T_{amb} \leq T_{max}$	0 0		$(V_{CC}^+)-1.5$ $(V_{CC}^+)-2$	V
Common Mode Rejection Ratio	CMRR	$T_{amb}=25$ $T_{min} \leq T_{amb} \leq T_{max}$	70 60	85		dB
Output Current Source	I_{source}	$V_{CC}=+15V,$ $V_O=2V, V_{id}=+1V$	30	50		mA
Short Circuit to Ground	I_o	$V_{CC}=+15V,$		50	70	mA
Output Current Sink	I_{sink}	$V_{id}=-1V,$ $V_{CC}=+15V, V_O=-2V$	7	10		mA
High Level Output Voltage	V_{OH}	$V_{CC}^+=30V$ $T_{amb}=25, R_L=10K$ $T_{min} \leq T_{amb} \leq T_{max}$	27 27	28		V
Low Level Output Voltage	V_{OL}	$R_L=10K$ $T_{min} \leq T_{amb} \leq T_{max}$		3	20 20	mV
Slew Rate at Unity Gain	SR	$V_i=0.5$ to $3V, V_{CC}=15V$ $R_L=2K, C_L=100pF,$ Unity Gain	0.2	0.4		$V/\mu S$
Gain Bandwidth Product	GBP	$V_{CC}=30V, R_L=2K$ $C_L=100pF, f=100kHz,$ $V_{in}=10mV$	0.5	0.9		MHz
Total Harmonic Distortion	THD	$f=1kHz, A_v=20dB$ $R_L=2K, V_{CC}=30V$ $C_L=100pF, V_O=2V_{PP}$		0.02		%

DC ELECTRICAL CHARACTERISTICS (Cont.)

Voltage Reference

PARAMETER	SYMBOL	VALUE	UNIT
Cathode Current	I_k	1 to 100	mA

PARAMETER	SYMBOL	TEST CONDITIONS	MIN	TYP	MAX	UNIT
Reference Input Voltage	V_{ref}	FP103, $T_{amb}=25$ $T_{min} \leq T_{amb} \leq T_{max}$.	2.475 2.450	2.5	2.525 2.550	V
Reference Input Voltage Deviation Over Temperature Range	ΔV_{ref}	$V_{KA}=V_{ref}; I_k=10mA$ $T_{min} \leq T_{amb} \leq T_{max}$.		7	30	mV
Minimum Cathode Current for Regulation	I_{min}	$V_{KA}=V_{ref}$		0.2	1	mA
Dynamic Impedance (note 1)	$ Z_{KA} $	$V_{KA}=V_{ref}, \Delta I_k=1 \text{ to } 100mA,$ $f < 1KHz, \text{note1}$		0.2	0.5	

1.The dynamic impedance is defined as $Z_{KA} = \frac{V_{KA}}{I_k}$

Total Supply Current

PARAMETER	SYMBOL	TEST CONDITIONS	MIN	TYP	MAX	UNIT
Total Supply Current, excluding Current in the Voltage Reference	I_{CC}	$V_{CC}=+5V, \text{no load}$ $T_{min} < T_{amb} < T_{max}$ $V_{CC}=+30V, \text{no load}$ $T_{min} < T_{amb} < T_{max}$.		0.7	1.2 2	mA

TYPICAL CHARACTERISTICS

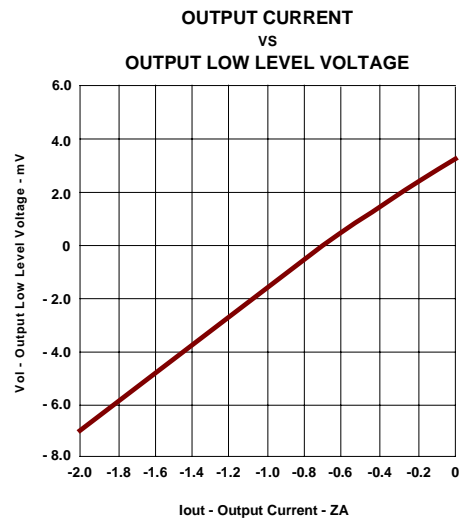
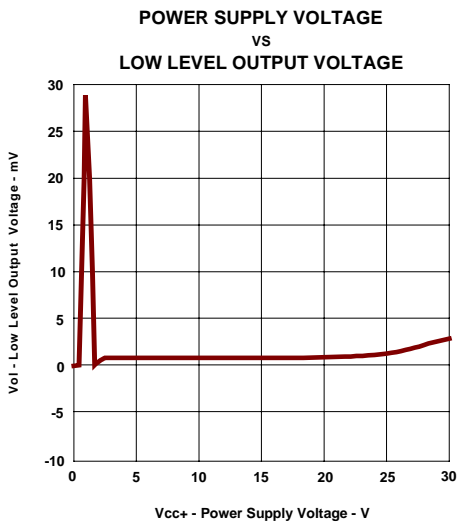
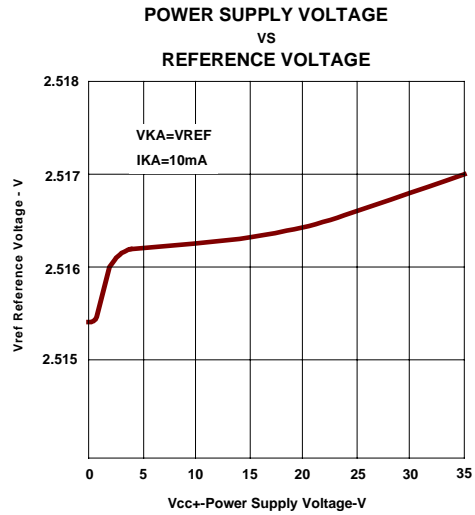
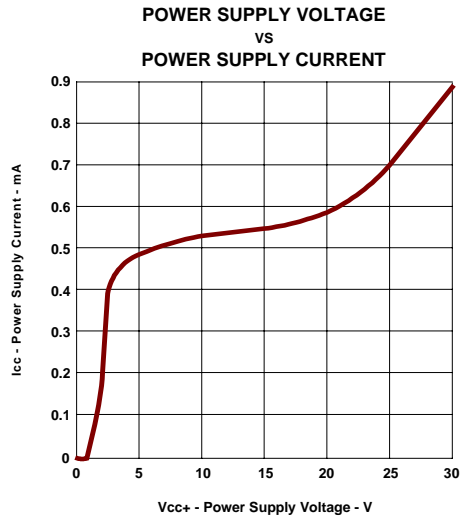
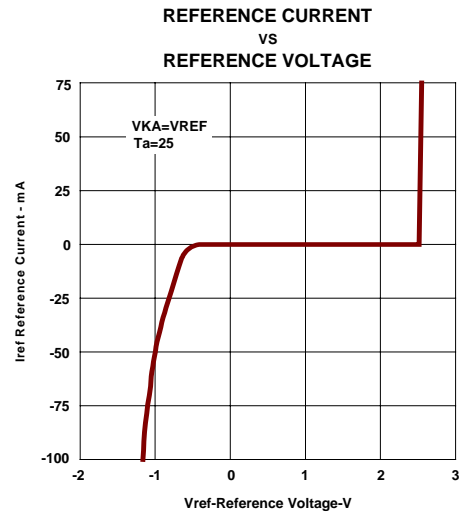
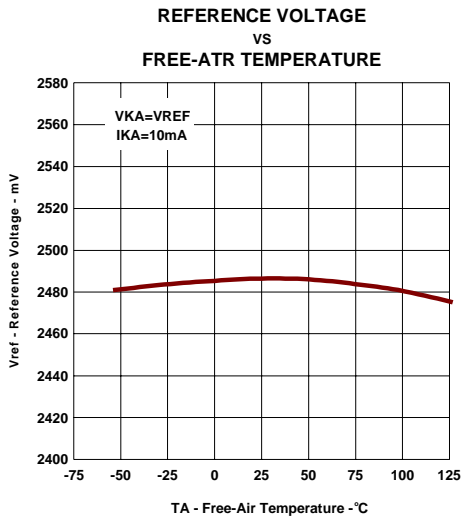

TYPICAL CHARACTERISTICS (Cont.)

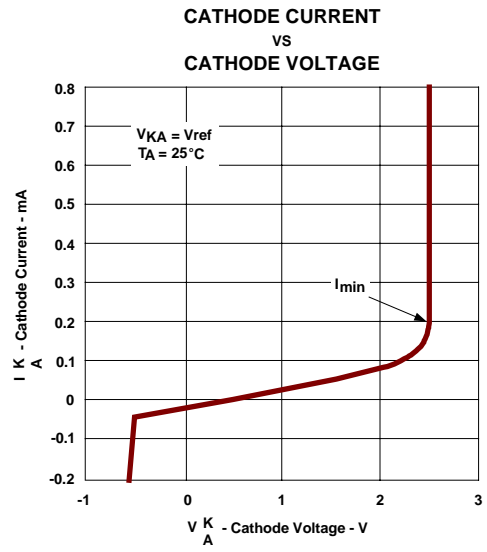
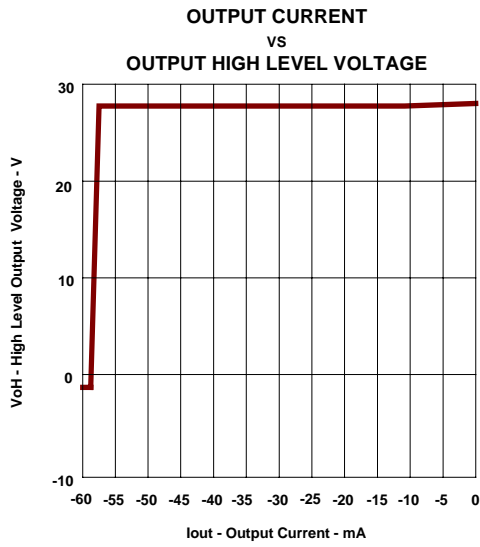

PACKAGE OUTLINE

SOP 8

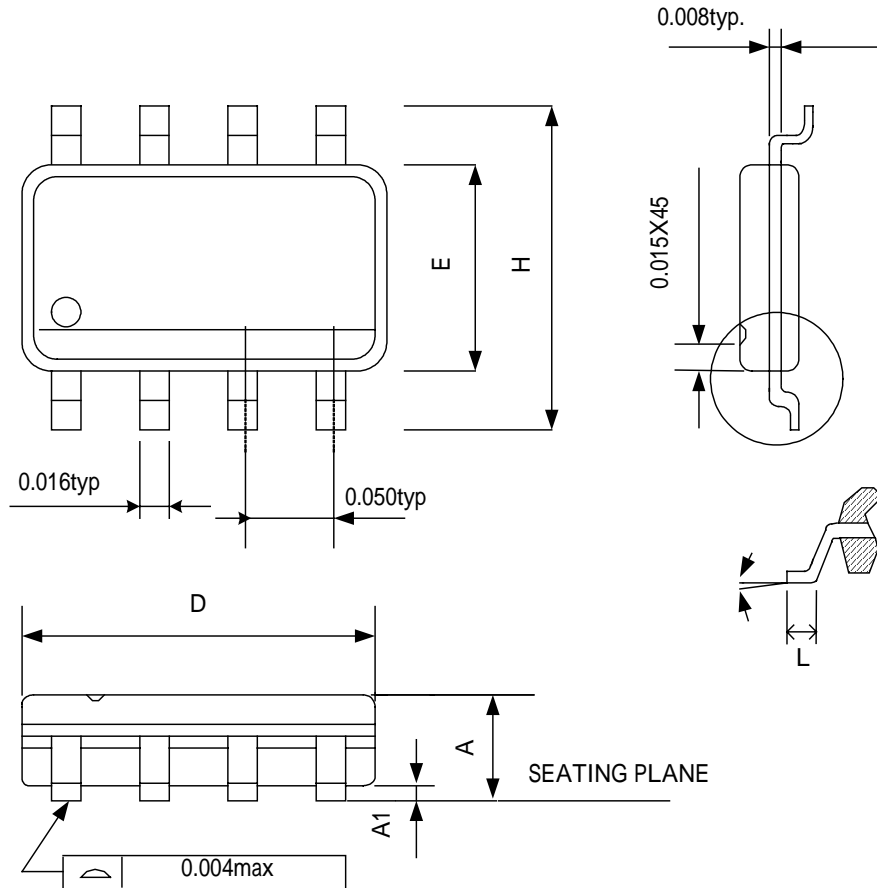

SYMBOLS	MIN	MAX
A	0.053	0.069
A1	0.004	0.010
D	0.189	0.196
E	0.150	0.157
H	0.228	0.244
L	0.016	0.050
°	0	8

UNIT:INCH

NOTE:

1. JEDEC OUTLINE:MS-012 AA
2. DIMENSIONS "D" DOES NOT INCLUDE MOLD FLASH,PROTRUSIONS OR GATE BURRS.MOLD FLASH,PROTRUSIONS AND GATE BURRS SHALL NOT EXCEED .15mm (.06in) PER SIDE
3. DIMENSIONS "E" DOES NOT INCLUDE INTER-LEAD FLASH,OR PROTRUSIONS. INTER-LEAD FLASH AND PROTRUSIONS SHALL NOT EXCEED .25mm (.0.10in) PER SIDE.

PDIP 8

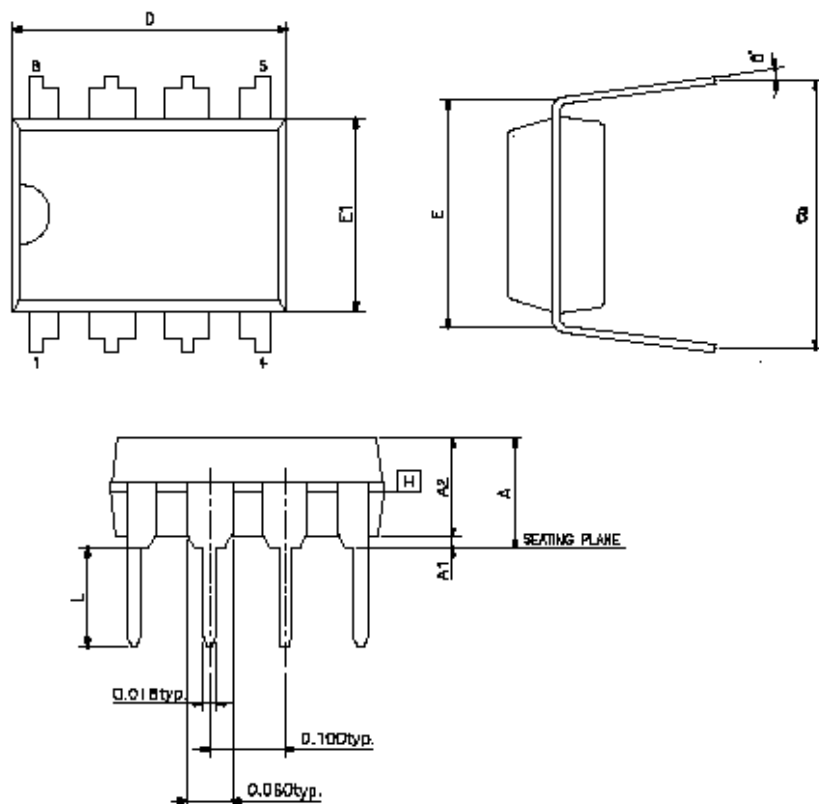

SYMBOLS	MIN	NOR	MAX
A	-	-	0.210
A1	0.015	-	-
A2	0.125	0.130	0.135
D	0.355	0.365	0.400
E	0.300BSC		
E1	0.245	0.250	0.255
L	0.115	0.130	0.150
e	0.335	0.355	0.375
°	0	7	15

UNIT:INCH

Note:

- JEDEC OUTLINE:MS-001 BA
- "D""E1" DIMENSIONS DO NOT INCLUDE MOLD FLASH OR PROTRUSIONS SHALL NOT EXCEED .010 INCH
- eB IS MEASURED AT THE LEAD TIPS WITH THE LEADS UNCONSTRAINED POINTED OR ROUNDED LEAD TIPS ARE PREFERRED TO EASE INSERTION
- DISTANCE BETWEEN LEADS INCLUDING DAM BAR PROTRUSIONS TO BE .005 INCH MINIMUM
- DATUM PLANE H COINCIDENT WITH THE BOTTOM OF LEAD, WHERE LEAD EXITS BODY.

PACKING SPECIFICATIONS

BOX DIMENSION

TUBE INSIDE BOX AND CARTON

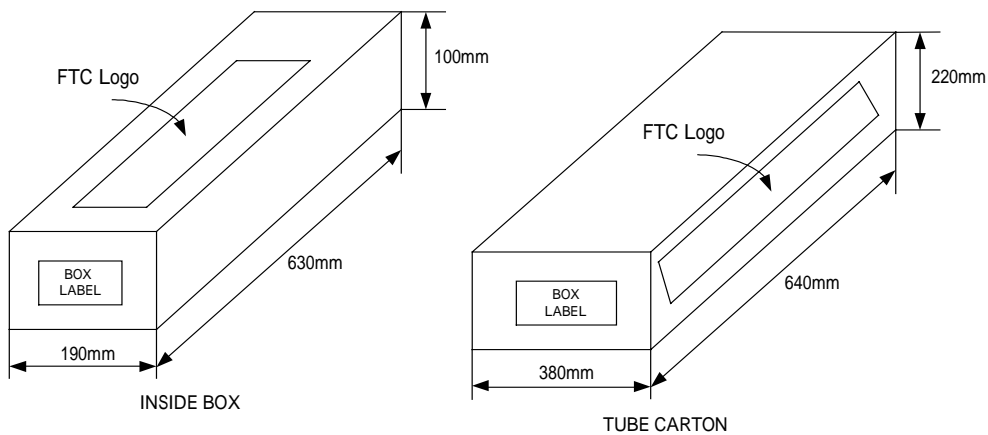

TAPE & REEL INSIDE BOX AND CARTON

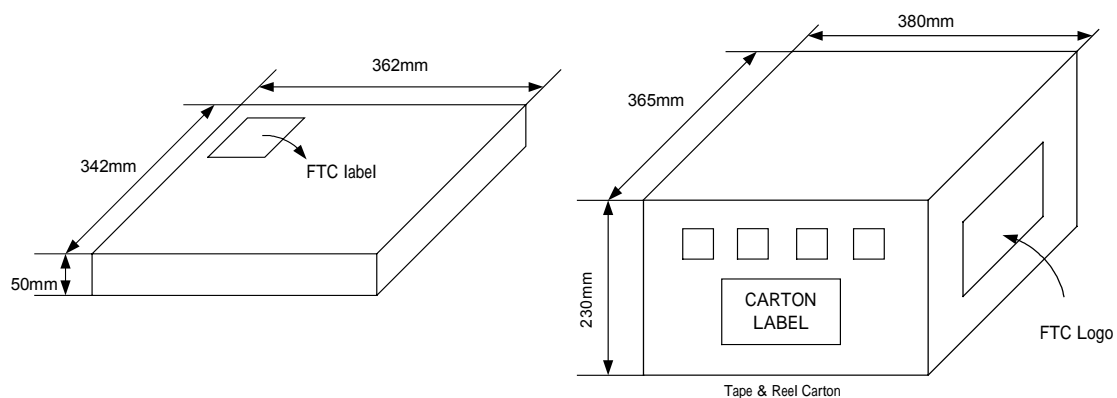

PACKING QUANTITY SPECIFICATIONS

100 EA / TUBE	2500 EA / REEL
100 TUBES / INSIDE BOX	4 INSIDE BOXES / CARTON
4 INSIDE BOXES / CARTON	

LABEL SPECIFICATIONS

TAPPING & REEL

Feeling Technology Corp. Product FP103 Lot No A3311C62 D/C 4Xx-XXL Q'ty	<div style="border: 1px solid black; padding: 2px; display: inline-block;"> 無鉛 Lead Free </div>
---	---

CARTON

Feeling Technology Corp.	
Product Type: FP103	
Lot No: A3311C62	
Date Code: 4Xx-XXL	
Package Type: SOP-8L	
Marking Type: Laser	<div style="border: 1px solid black; padding: 2px; display: inline-block;"> 無鉛 Lead Free </div>
Total Q'ty: 10,000	

CARRIER TAPE DIMENSIONS

APPLICATION	W	P	E	F	D	D ₁
SOP8	12.0 ^{+0.3} _{-0.1}	8.0±0.1	1.75±0.1	5.5±0.1	1.55±0.1	1.5 ^{+0.25}

APPLICATION	P ₀	P ₁	A ₀	B ₀	K ₀	t
SOP8	4.0±0.1	2.0±0.1	6.4±0.1	5.20±0.1	2.1±0.10	0.30±0.013

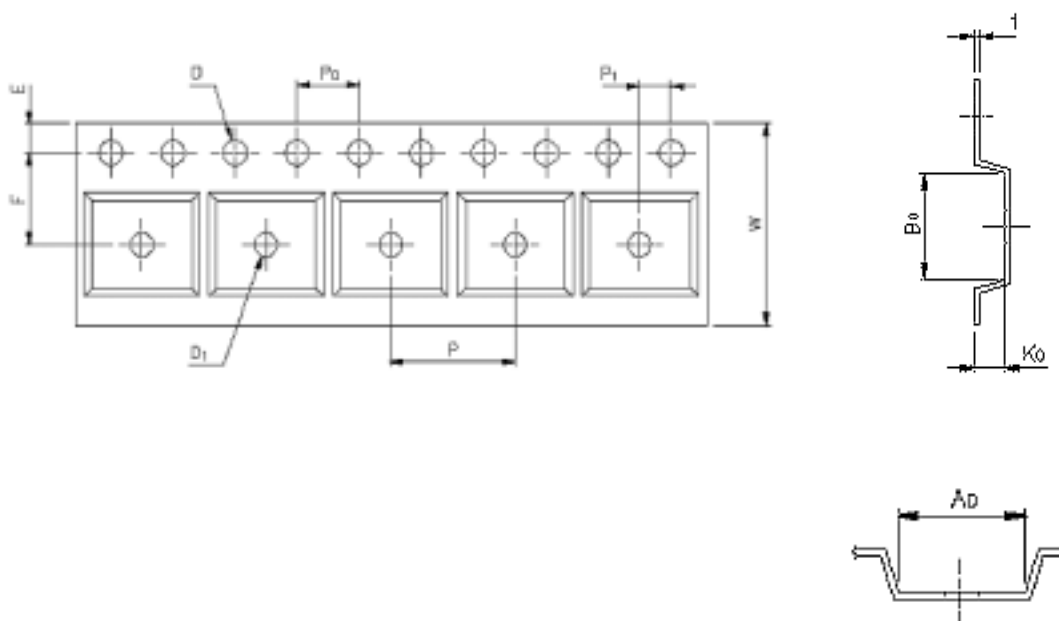

REEL DIMENSIONS

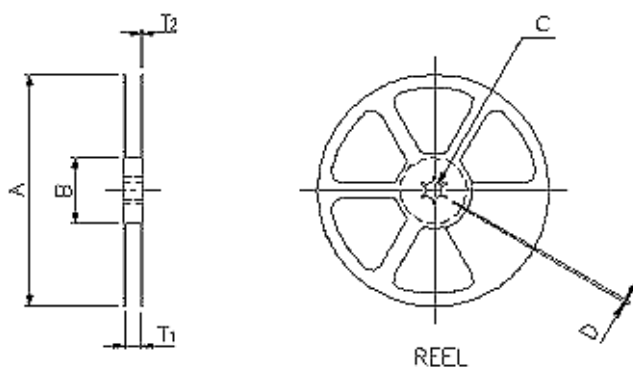

APPLICATION	MATERIAL	A	B	C	D	T ₁	T ₂
SOP8	PLASTIC REEL	330±0.1	62±1.5	12.75±0.15	2±0.6	12.4±0.2	2.0±0.2