

# AP28G45GEM

**Pb Free Plating Product**

*N-CHANNEL INSULATED GATE*

*BIPOLAR TRANSISTOR*



**Advanced Power  
Electronics Corp.**

- ▼ High Input Impedance
- ▼ High Pick Current Capability
- ▼ 3.3V Gate Drive
- ▼ Strobe Flash Applications

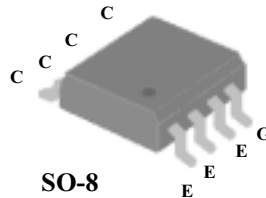

$V_{CE}$	450V
$I_{CP}$	130A

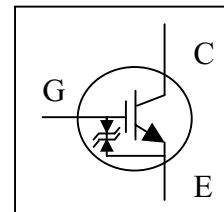

## Absolute Maximum Ratings

Symbol	Parameter	Rating	Units
$V_{CE}$	Collector-Emitter Voltage	450	V
$V_{GE}$	Gate-Emitter Voltage	$\pm 6$	V
$I_{GEP}$	Pulsed Gate-Emitter Voltage	$\pm 8$	V
$I_{CP}$	Pulsed Collector Current, $V_{GE} @ 3.3V$	130	A
$P_D @ T_C = 25^\circ C^1$	Maximum Power Dissipation	2.5	W
$T_{STG}$	Storage Temperature Range	-55 to 150	$^\circ C$
$T_J$	Operating Junction Temperature Range	-55 to 150	$^\circ C$

## Electrical Characteristics @ $T_J = 25^\circ C$ (unless otherwise specified)

Symbol	Parameter	Test Conditions	Min.	Typ.	Max.	Units
$I_{GES}$	Gate-Emitter Leakage Current	$V_{GE} = \pm 6V, V_{CE} = 0V$	-	-	10	$\mu A$
$I_{CES}$	Collector-Emitter Leakage Current	$V_{CE} = 450V, V_{GE} = 0V$	-	-	10	$\mu A$
$V_{CE(sat)}$	Collector-Emitter Saturation Voltage	$V_{GE} = 3.3V, I_{CP} = 130A$ (Pulsed)	-	3.8	6	V
$V_{GE(th)}$	Gate Threshold Voltage	$V_{CE} = V_{GE}, I_C = 250\mu A$	-	-	1	V
$Q_g$	Total Gate Charge	$I_C = 40A$	-	74	120	nC
$Q_{ge}$	Gate-Emitter Charge	$V_{CE} = 360V$	-	8	-	nC
$Q_{gc}$	Gate-Collector Charge	$V_{GE} = 4.5V$	-	34	-	nC
$t_{d(on)}$	Turn-on Delay Time	$V_{CC} = 200V$	-	20	-	ns
$t_r$	Rise Time	$I_C = 15A$	-	100	-	ns
$t_{d(off)}$	Turn-off Delay Time	$R_G = 10\Omega$	-	400	-	ns
$t_f$	Fall Time	$V_{GE} = 5V$	-	3	-	$\mu s$
$C_{ies}$	Input Capacitance	$V_{GE} = 0V$	-	3020	4830	pF
$C_{oes}$	Output Capacitance	$V_{CE} = 25V$	-	220	-	pF
$C_{res}$	Reverse Transfer Capacitance	$f = 1.0MHz$	-	50	-	pF
$R_{thJA}^1$	Thermal Resistance Junction-Ambient		-	-	50	$^\circ C/W$

### Notes:

1. Surface mounted on 1 in<sup>2</sup> copper pad of FR4 board ; 125 $^\circ C/W$  when mounted on Min. copper pad.

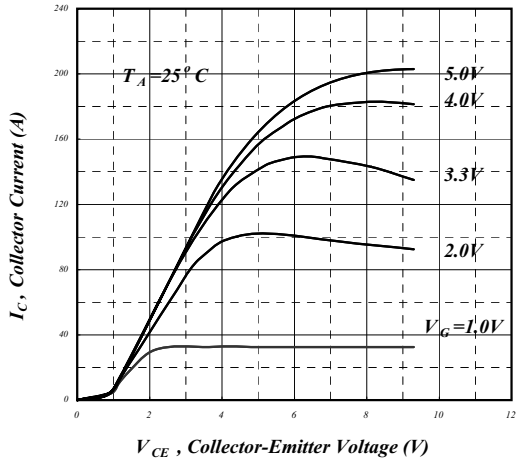

Fig 1. Typical Output Characteristics

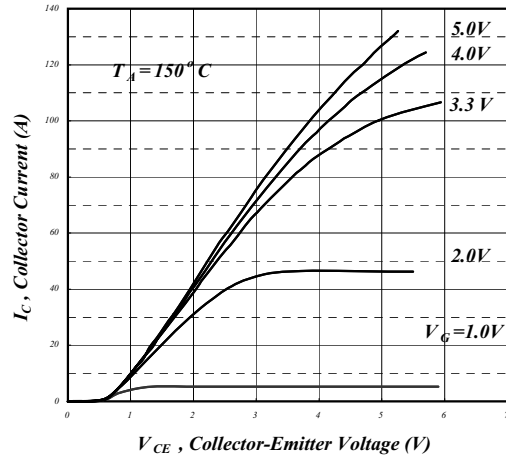

Fig 2. Typical Output Characteristics

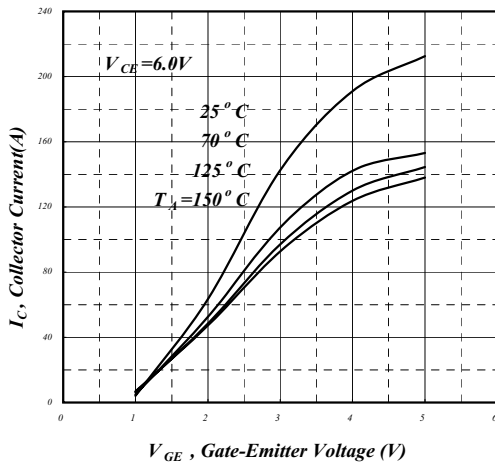

Fig 3. Collector Current v.s. Gate-Emitter Voltage

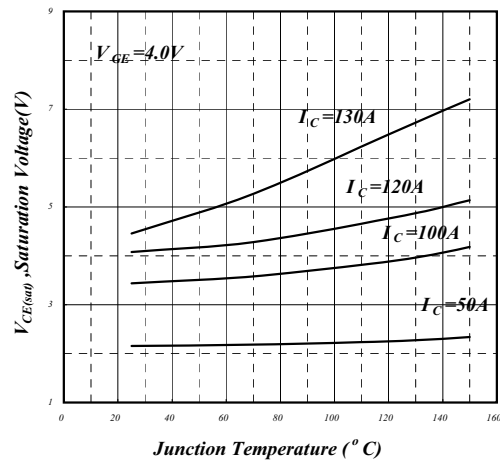

Fig 4. Collector- Emitter Saturation Voltage v.s. Junction Temperature

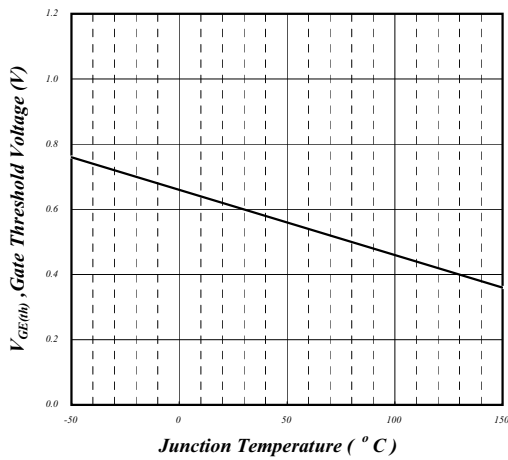

Fig 5. Gate Threshold Voltage v.s. Junction Temperature

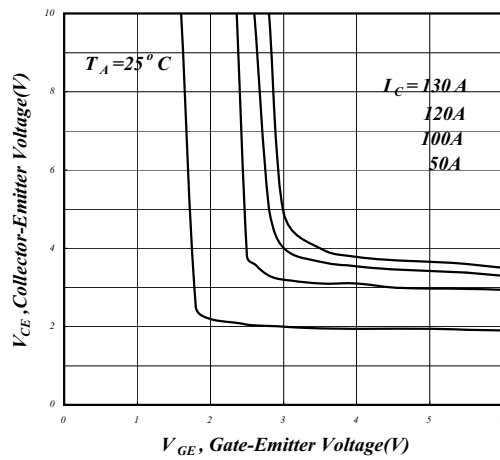

Fig 6. Collector Current v.s. Gate-Emitter Voltage

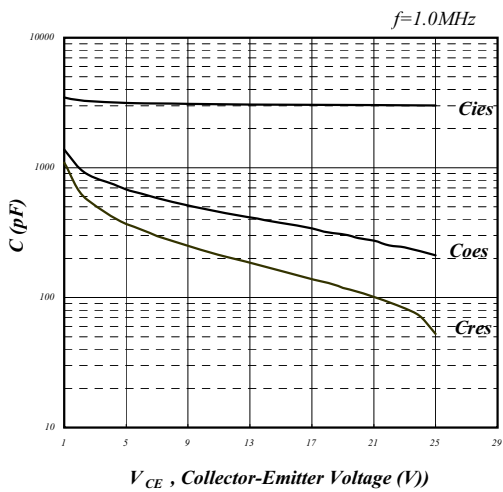

Fig 7. Typical Capacitance Characteristics

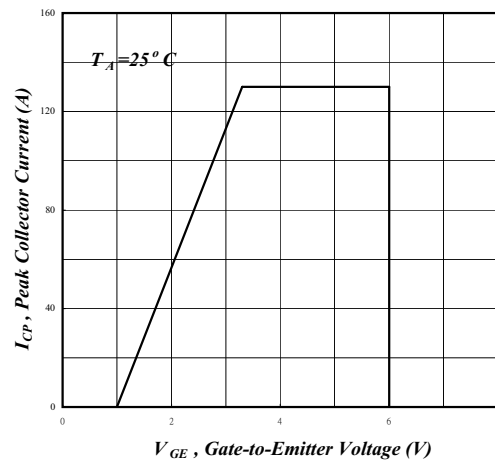

Fig 8. Maximum Pulse Collector Current

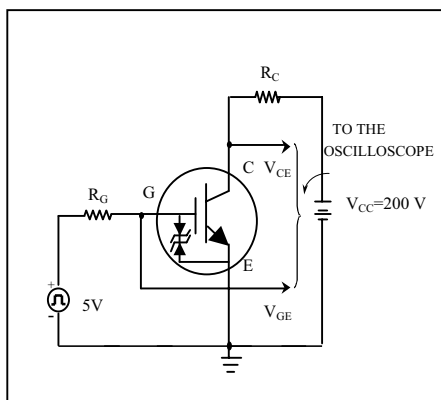

Fig 9. Switching Time Test Circuit

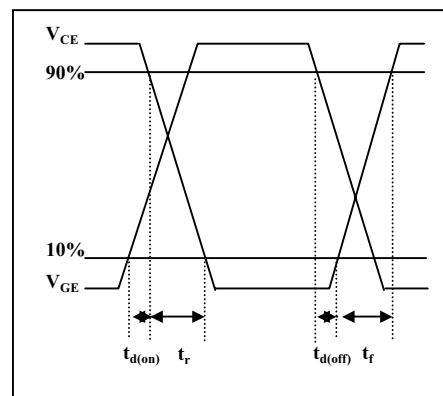

Fig 10. Switching Time Waveform

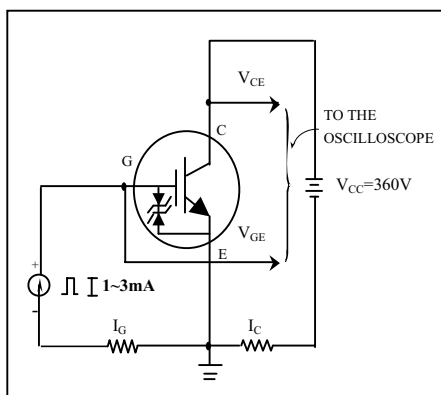

Fig 11. Gate Charge Test Circuit

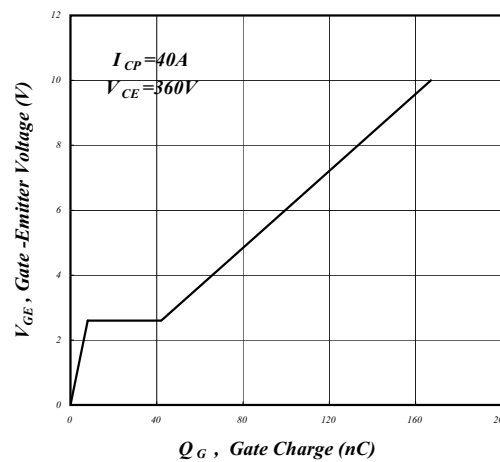

Fig 12. Gate Charge Waveform