



Advanced Power Electronics Corp.

AP2304AGN

Pb Free Plating Product

N-CHANNEL ENHANCEMENT MODE

POWER MOSFET

- ▼ Simple Drive Requirement
- ▼ Small Package Outline
- ▼ Surface Mount Device

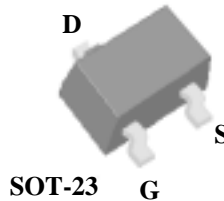

BV_{DSS}	30V
$R_{DS(ON)}$	117m Ω
I_D	2.5A

Description

Advanced Power MOSFETs utilized advanced processing techniques to achieve the lowest possible on-resistance, extremely efficient and cost-effectiveness device.

The SOT-23 package is universally used for all commercial-industrial applications.

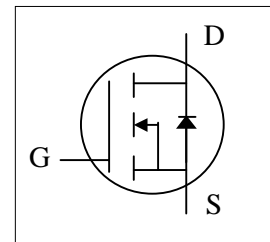

Absolute Maximum Ratings

Symbol	Parameter	Rating	Units
V_{DS}	Drain-Source Voltage	30	V
V_{GS}	Gate-Source Voltage	± 20	V
$I_D @ T_A = 25^\circ C$	Continuous Drain Current ³ , $V_{GS} @ 10V$	2.5	A
$I_D @ T_A = 70^\circ C$	Continuous Drain Current ³ , $V_{GS} @ 10V$	2	A
I_{DM}	Pulsed Drain Current ¹	10	A
$P_D @ T_A = 25^\circ C$	Total Power Dissipation	1.38	W
	Linear Derating Factor	0.01	W/ $^\circ C$
T_{STG}	Storage Temperature Range	-55 to 150	$^\circ C$
T_J	Operating Junction Temperature Range	-55 to 150	$^\circ C$

Thermal Data

Symbol	Parameter	Value	Unit
R_{thj-a}	Thermal Resistance Junction-ambient ³ Max.	90	$^\circ C/W$



Electrical Characteristics @T_j=25°C(unless otherwise specified)

Symbol	Parameter	Test Conditions	Min.	Typ.	Max.	Units
BV_{DSS}	Drain-Source Breakdown Voltage	$V_{GS}=0V, I_D=250\mu A$	30	-	-	V
$\Delta BV_{DSS}/\Delta T_j$	Breakdown Voltage Temperature Coefficient	Reference to 25°C, $I_D=1mA$	-	0.1	-	V/°C
$R_{DS(ON)}$	Static Drain-Source On-Resistance ²	$V_{GS}=10V, I_D=2.5A$	-	-	117	mΩ
		$V_{GS}=4.5V, I_D=2A$	-	-	190	mΩ
$V_{GS(th)}$	Gate Threshold Voltage	$V_{DS}=V_{GS}, I_D=250\mu A$	1	-	3	V
g_{fs}	Forward Transconductance	$V_{DS}=10V, I_D=2.5A$	-	2	-	S
I_{DSS}	Drain-Source Leakage Current (T _j =25°C)	$V_{DS}=30V, V_{GS}=0V$	-	-	1	uA
	Drain-Source Leakage Current (T _j =70°C)	$V_{DS}=24V, V_{GS}=0V$	-	-	10	uA
I_{GSS}	Gate-Source Leakage	$V_{GS}=\pm 20V$	-	-	±100	nA
Q_g	Total Gate Charge ²	$I_D=2.5A$	-	3	5	nC
Q_{gs}	Gate-Source Charge	$V_{DS}=24V$	-	0.8	-	nC
Q_{gd}	Gate-Drain ("Miller") Charge	$V_{GS}=4.5V$	-	1.8	-	nC
$t_{d(on)}$	Turn-on Delay Time ²	$V_{DS}=15V$	-	5	-	ns
t_r	Rise Time	$I_D=1A$	-	9	-	ns
$t_{d(off)}$	Turn-off Delay Time	$R_G=3.3\Omega, V_{GS}=10V$	-	11	-	ns
t_f	Fall Time	$R_D=15\Omega$	-	2	-	ns
C_{iss}	Input Capacitance	$V_{GS}=0V$	-	120	190	pF
C_{oss}	Output Capacitance	$V_{DS}=25V$	-	62	-	pF
C_{rss}	Reverse Transfer Capacitance	$f=1.0MHz$	-	24	-	pF
R_g	Gate Resistance	$f=1.0MHz$	-	1.67	-	Ω

Source-Drain Diode

Symbol	Parameter	Test Conditions	Min.	Typ.	Max.	Units
V_{SD}	Forward On Voltage ²	$I_S=1.2A, V_{GS}=0V$	-	-	1.2	V
t_{rr}	Reverse Recovery Time ²	$I_S=2A, V_{GS}=0V,$	-	24	-	ns
Q_{rr}	Reverse Recovery Charge	$di/dt=100A/\mu s$	-	23	-	nC

Notes:

- 1.Pulse width limited by Max. junction temperature.
- 2.Pulse width ≤300us , duty cycle ≤2%.
- 3.Surface mounted on 1 in² copper pad of FR4 board ; 270°C/W when mounted on min. copper pad.

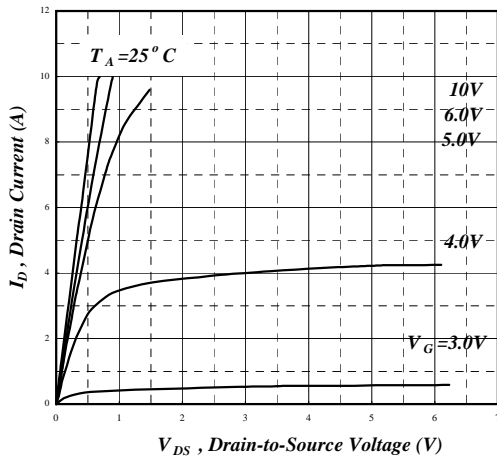

Fig 1. Typical Output Characteristics

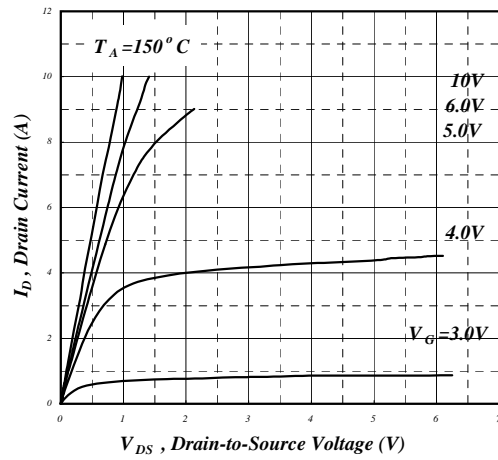

Fig 2. Typical Output Characteristics

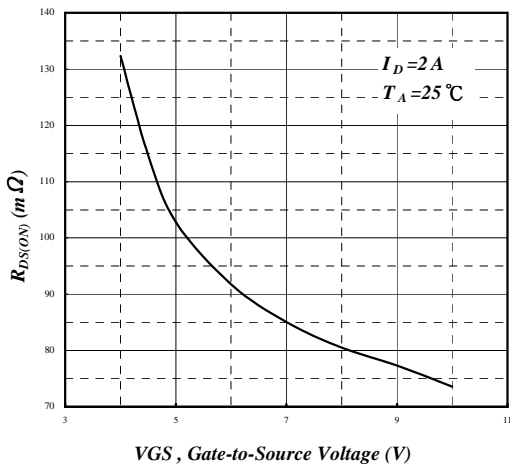

Fig 3. On-Resistance v.s. Gate Voltage

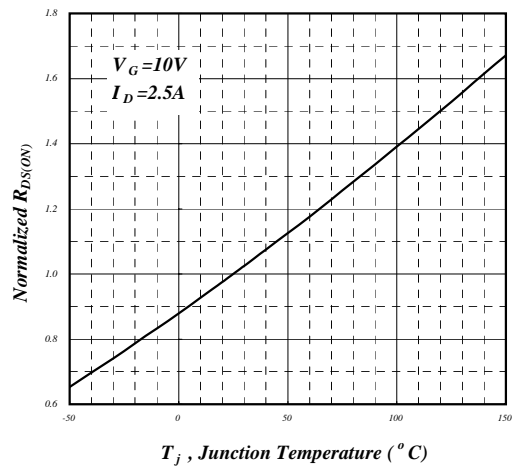

Fig 4. Normalized On-Resistance

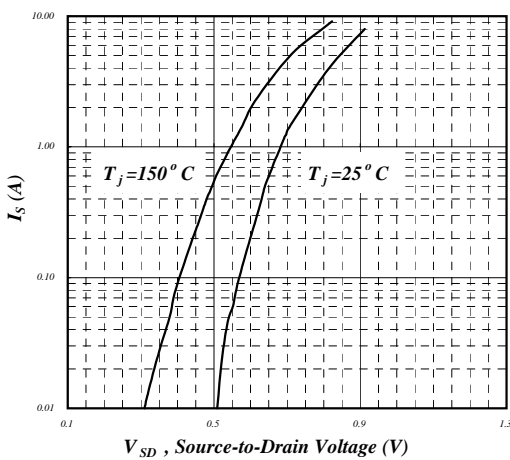

Fig 5. Forward Characteristic of Reverse Diode

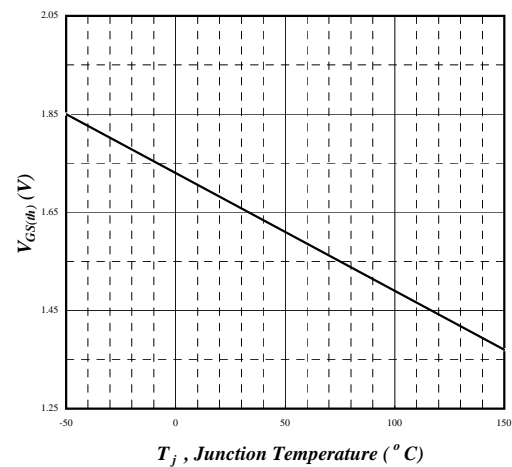

Fig 6. Gate Threshold Voltage v.s. Junction Temperature

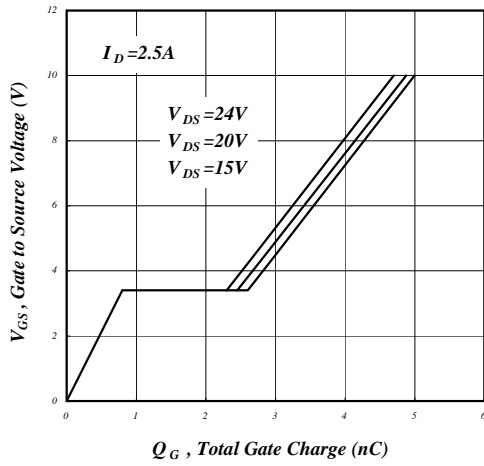

Fig 7. Gate Charge Characteristics

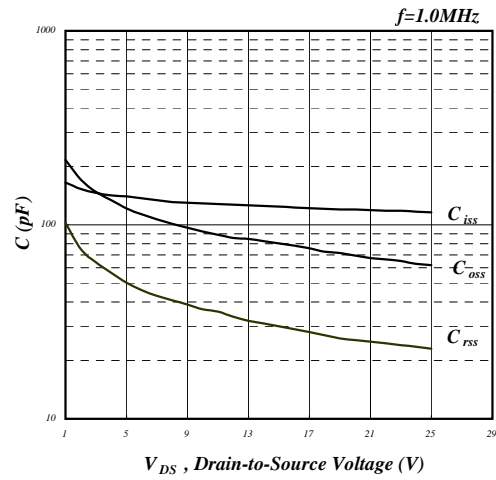

Fig 8. Typical Capacitance Characteristics

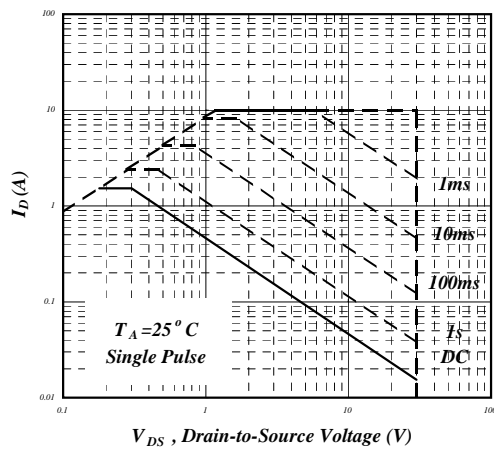

Fig 9. Maximum Safe Operating Area

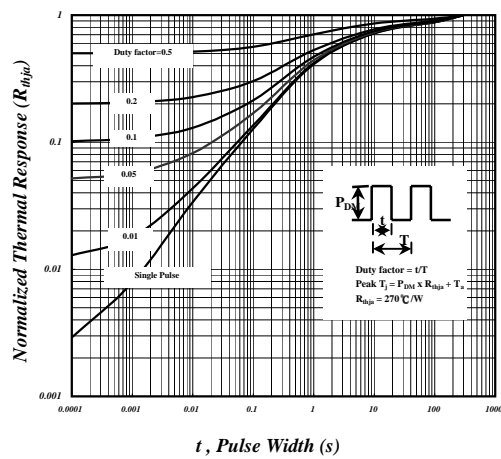

Fig 10. Effective Transient Thermal Impedance

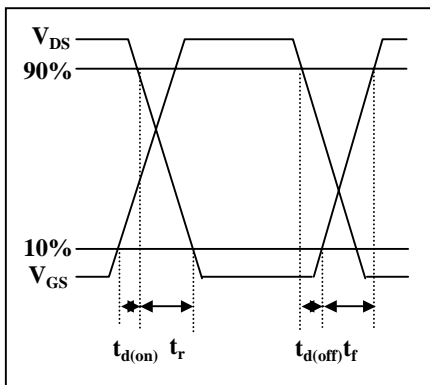

Fig 11. Switching Time Waveform

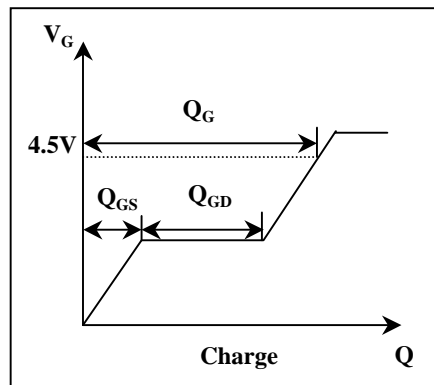
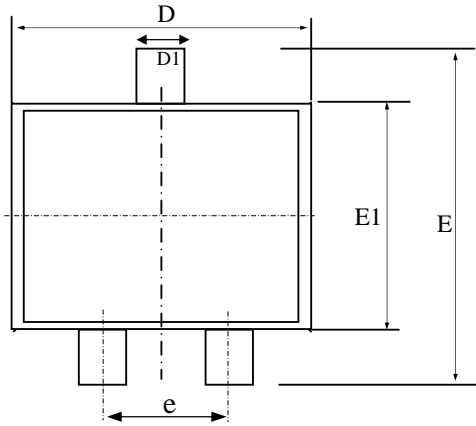

Fig 12. Gate Charge Waveform

富鼎先進電子股份有限公司
Package產品尺寸圖

Package Outline : SOT-23



SYMBOLS	Millimeters		
	MIN	NOM	MAX
A	1.00	1.15	1.30
A1	0.00	--	0.10
A2	0.10	0.15	0.20
D1	0.30	0.40	0.50
e	1.70	2.00	2.30
D	2.70	2.90	3.10
E	2.40	2.65	2.90
E1	1.40	1.50	1.60

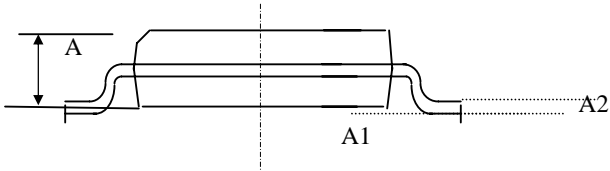

- 1.All Dimension Are In Millimeters.
- 2.Dimension Does Not Include Mold Protrusions.

Part Marking Information & Packing : SOT-23

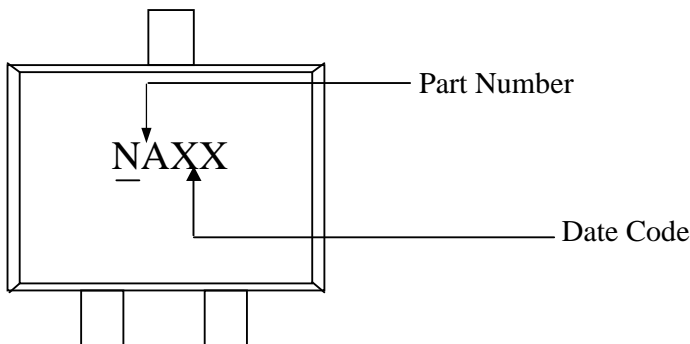

*Packing (antistatic)
Reel : 3000pcs/reel ; 5reel/box ; 10box/carton

富鼎先進電子股份有限公司

包裝規範

5.2.2.1

產品型式	TO-252/SOT-223	TO-263	SO-8/TSSOP-8	SOT-23	SOT-89
單捲數量	3000ea	800ea	3000ea	3000ea	1000ea
內盒數量	6000ea/Box	800ea/box	6000ea/box	15000ea/box	5000ea/box
外箱數量	24000ea/carton	4000ea/carton	24000 or 48000ea/carton	150000ea/carton	50000ea/carton
外箱尺寸	附件(二)	附件(二)	附件(六)	附件(二)	附件(二)
圓盤規格	附圖一/附圖六	附圖三	附圖二	附圖四	附圖五

5.2.2.2 尾數箱裝箱時需將剩餘空間，以小內盒或氣泡膠填充之。

5.2.3 靜電袋之裝箱法

產品型式	TO-220	TO-251/TO-92
單包數量	50ea	100ea
內盒數量	500ea/box	10000ea/box
外箱數量	4000ea/carton	40000ea/carton
外箱尺寸	附件(三)	附件(四)

5.2.3.2 尾數箱裝箱時需將剩餘空間，以小內盒氣泡膠填充之。

5.3 不同產品不可裝入同一箱子內，以避免產品混料。

5.4 包裝箱標籤：整貨裝箱後將型號數量標籤(如附件五)貼在紙箱及小內盒側面。

5.5 包裝檢驗：裝箱完成後通知 QA 檢驗，檢驗合格則蓋上檢查合格章後等待出貨。

6. 相關文件：無

7. 使用表單：無

富鼎先進電子股份有限公司 包裝規範

附件二： TO-252、TO-263、**SOT-23**、SOT-89 & SOT-223

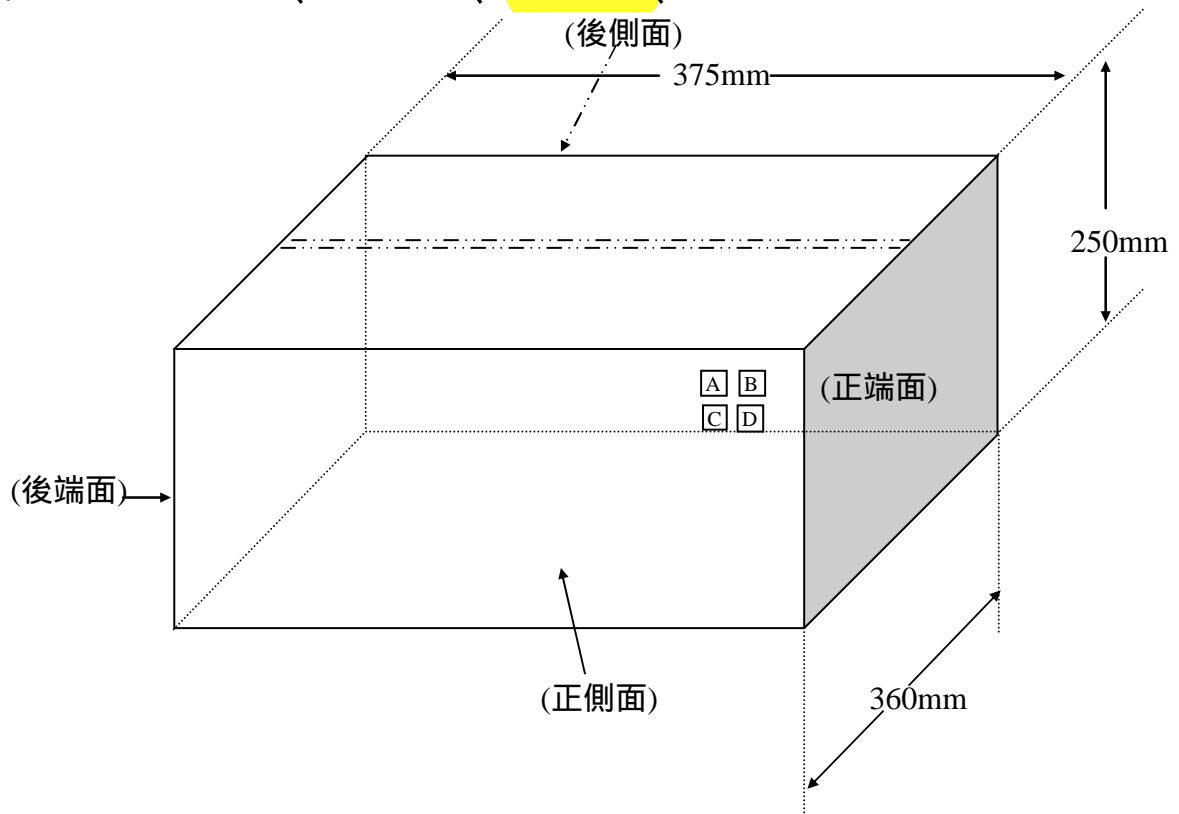

(一)正側面及後側面

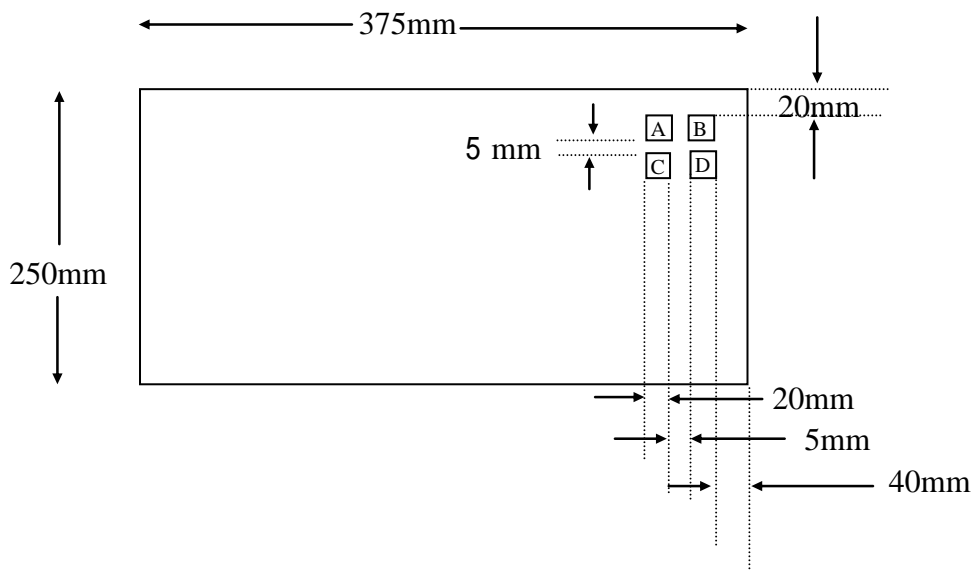

富鼎先進電子股份有限公司

包裝規範

1.A、B、C、D為警告標誌，各20mm*20mm

(一) 圖案如下：TO-252、TO-263、SOT-23、SOT-89 & SOT-223

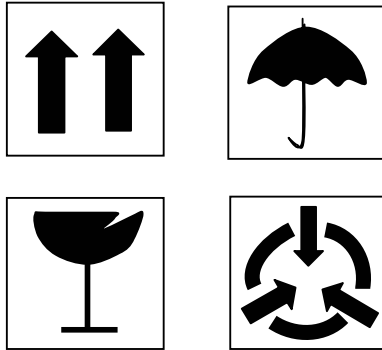

(二) 正端面

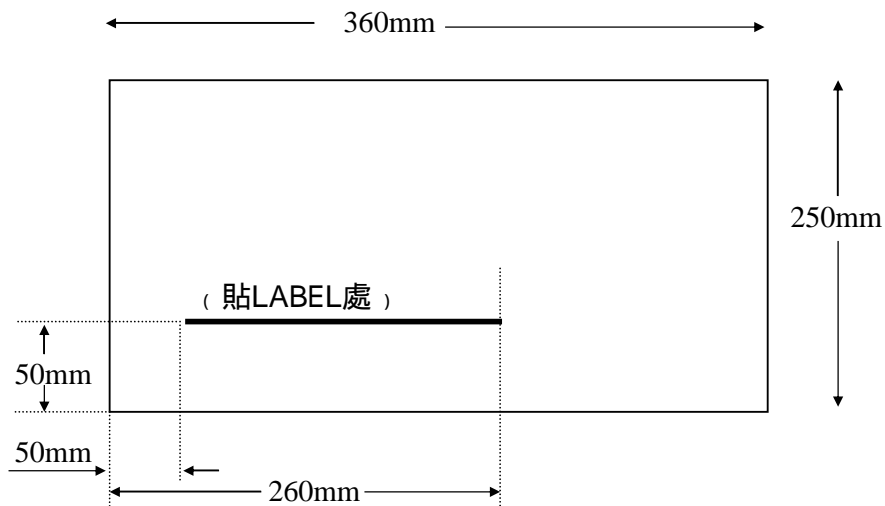

1.LABEL 下緣與標線貼齊

2.標線尺寸1.5mm*210mm

富鼎先進電子股份有限公司

包裝規範

附圖四：
SOT-23 Tape & Reel Information

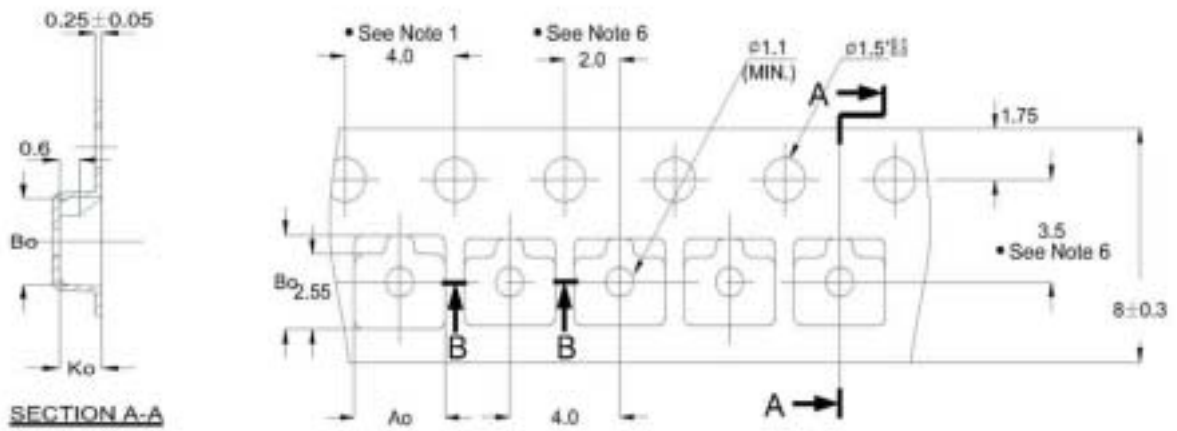

Notes:

1. 10 sprocket hole pitch cumulative tolerance: ± 0.2
2. Camber not to exceed 1mm in 100mm.
3. Material: Black Adventek Polystyrene.
4. A_o and B_o measured on a plane 0.3mm above the bottom of the pocket.
5. K_o measured from a plane on the inside bottom of the pocket to the top surface of the carrier.
6. Pocket position relative to sprocket hole measured as true position of pocket, not pocket hole.

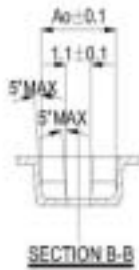

$A_o=3.30\text{mm}$
 $B_o=3.20\text{mm}$
 $K_o=1.47\text{mm}$

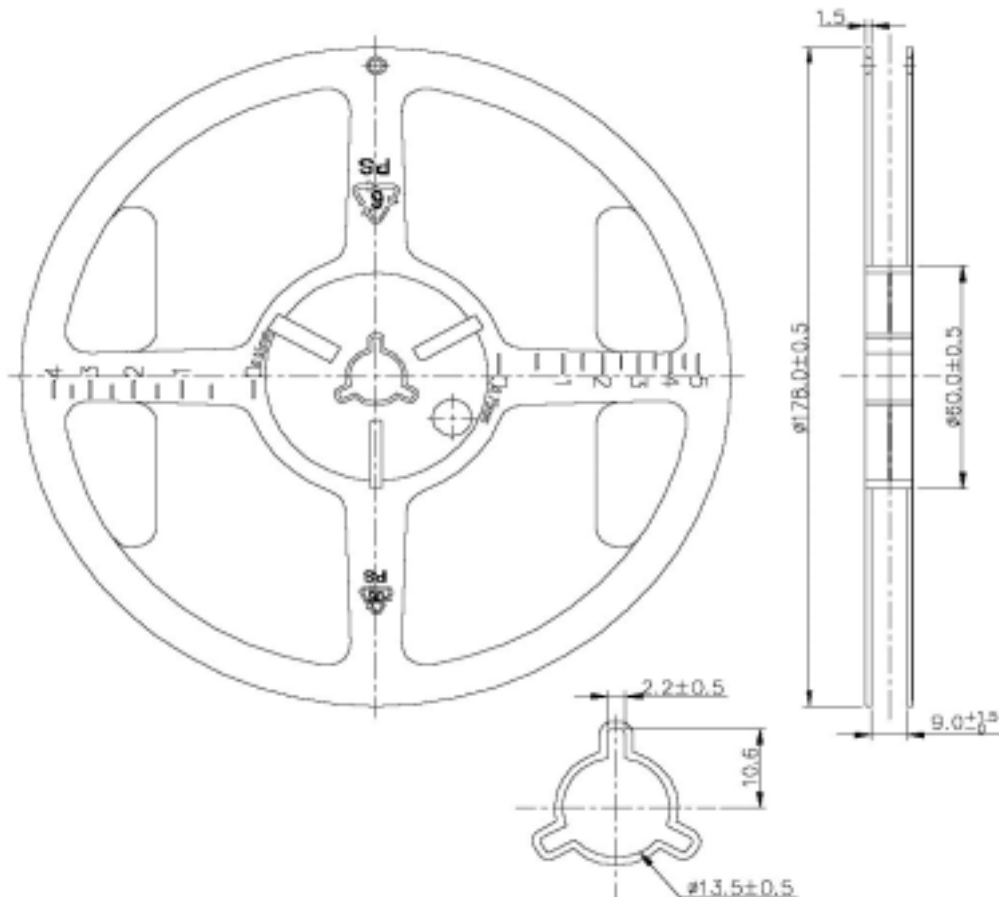



富鼎先進電子股份有限公司
ADVANCED POWER ELECTRONICS CORP.

SOT Series D/C Description

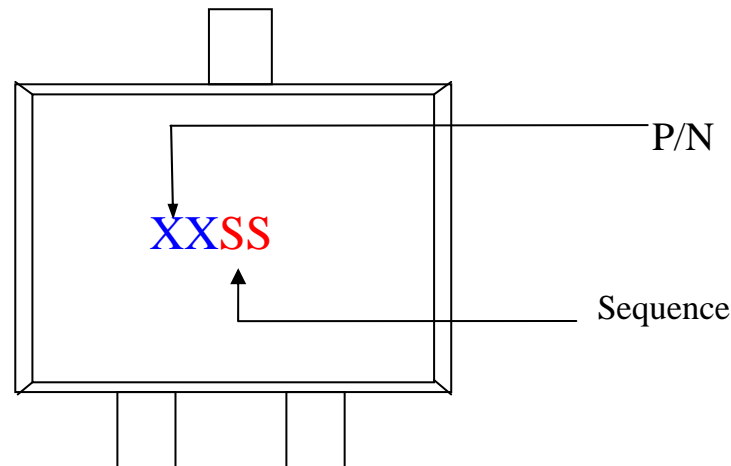

- (1) “XX” is the P/N code
- (2) “SS” is the Sequence:
當 S 為阿拉伯數字 “1~9 或小寫 a-z” 代表流水編號, 即代表當週第幾生產批
當 S 為大寫之 ” A-Z ” 代表週別碼, 如於第三碼則為 1-26 週, 如於第四碼則 27-52 週
- (3) Add the under line in first Alphabet for Pb-free Product.

Ex(1)Y5B1:mean AP2605Y mean the first lot produce in the second week

(2)Y52B: mean AP2605Y mean the second lot produce in the 28th week

(3) Y5B1:mean AP2605Y produce in the second week for Pb-free product.

SOT Series Year Code			
<div style="border: 1px solid black; padding: 5px; display: inline-block;"> X X S S </div>	2004,2008,2012...	<div style="border: 1px solid black; padding: 5px; display: inline-block;"> XXSS<u> </u> </div>	2005,2009,2013...
<div style="border: 1px solid black; padding: 5px; display: inline-block;"> X X <u> </u> S S </div>	2006,2010,2014...	<div style="border: 1px solid black; padding: 5px; display: inline-block;"> X X <u> </u> <u> </u> S S </div>	2007,2011,2015...

4 years in one cycle

- EX:Y5B2 :表示2004年第二週第二批之產品
- EX:Y5B2 :表示2005年第二週第二批之產品
- EX:Y5B2 :表示2006年第二週第二批之產品
- EX:Y5B2 :表示2007年第二週第二批之產品

SOT- D/C 說明

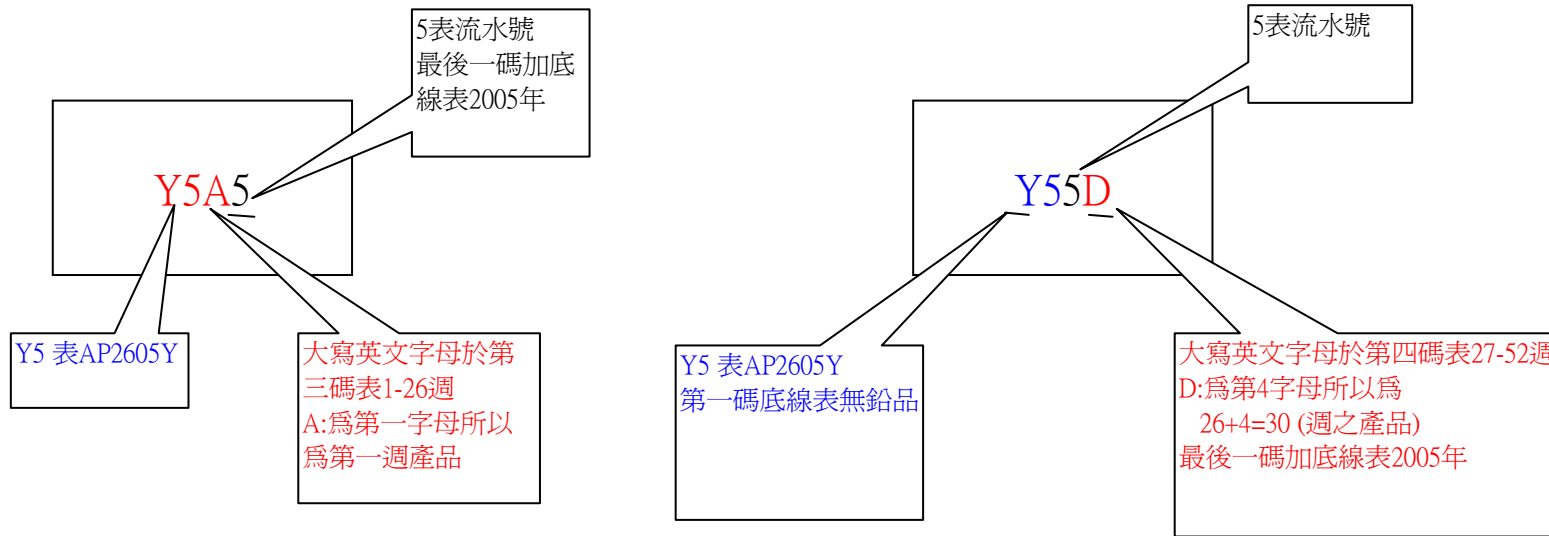

原廠商:APEC

此D/C編碼適應範圍:SOT-23、SOT-26

D/C欄位的第一、二碼表示P/N

D/C欄位的第三、四碼表示週別&流水碼

EX:

D/C: N3K5

N1:表AP2303
K:依對照表顯示為11週
5:表當週第5生產批

D/C:N35K

N1:表AP2303
K:依對照表顯示為37週
5:表當週第5生產批

D/C:Y3F1

Y3 表AP2603
F:依對照表顯示為6週
1:表當週第1生產批

大寫英文字 母於第三碼	對應週別	大寫英文字 母於第四碼	對應週別
A	1	A	27
B	2	B	28
C	3	C	29
D	4	D	30
E	5	E	31
F	6	F	32
G	7	G	33
H	8	H	34
I	9	I	35
J	10	J	36
K	11	K	37
L	12	L	38
M	13	M	39
N	14	N	40
O	15	O	41
P	16	P	42
Q	17	Q	43
R	18	R	44
S	19	S	45
T	20	T	46
U	21	U	47
V	22	V	48
W	23	W	49
X	24	X	50
Y	25	Y	51
Z	26	Z	52