



General Description

APE1803A consists of step-down switching regulator with PWM control. These device include a reference voltage source, oscillation circuit, error amplifier, internal PMOS and etc.

APE1803A provides low-ripple power, high efficiency, and excellent transient characteristics. The PWM control circuit is able to vary the duty ratio linearly from 0 up to 100%. This converter also contains an error amplifier circuit as well as a soft-start circuit that prevents overshoot at startup. An enable function, an over current protect function and short circuit protect function are built inside, and when OCP or SCP happens, the operation frequency will be reduced. Also, an internal compensation block is built in to minimum external component count.

With the addition of an internal P-channel Power MOS, a coil, capacitors, and a diode connected externally, these ICs can function as step-down switching regulators. They serve as ideal power supply units for portable devices when coupled with the SOP-8 package, providing such outstanding features as low current consumption. Since this converter can accommodate an input voltage up to 23V, it is also suitable for the operation via an AC adapter.

Features

- Input voltage : 3.6V to 23V
- Output voltage : 0.8V to Vcc
- Duty ratio : 0% to 100% PWM control
- Oscillation frequency : 330KHz typ.
- Soft-start(SS), Current Limit(CL), Enable function.
- Thermal Shutdown function.
- Short Circuit Protect (SCP).
- Built-in internal SW P-channel MOS.
- Low ESR output capacitor (Multi-layer chip capacitor (MLCC)) application.
- SOP-8 package.
- RoHS Compliant



Block Diagram

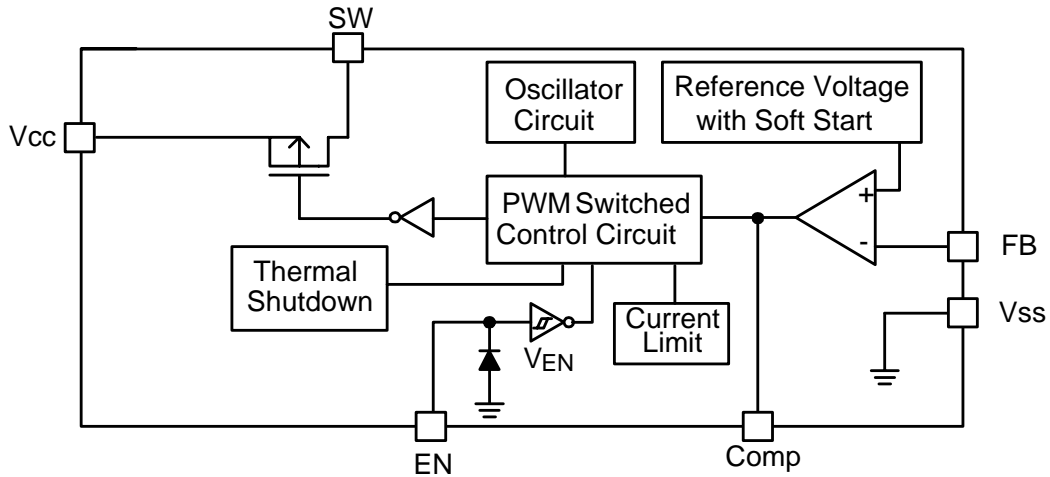

PIN Assignment

The package of APE1803A is SOP-8; the pin assignment is given by:

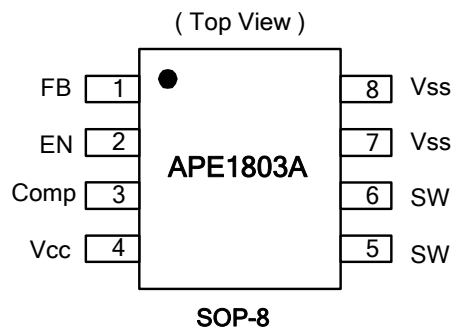

Name	Description
FB	Feedback pin
EN	Power-off pin H : normal operation(Step-down) L : Step-down operation stopped (All circuits deactivated)
Comp	Compensation pin
V _{cc}	IC power supply pin
SW	Switch pin. Connect external inductor/diode here.
V _{ss}	GND pin

Order/Marking Information

Order Information	Top Marking
<p>APE1803AX</p> <p>Package Type M: SOP-8</p>	<p>1803AM → Part number</p> <p>Y WW SSS → Sequence no.</p> <p>Xth Week: 01~52</p> <p>Year: 6 = 2006</p>



Absolute Maximum Ratings (at Ta=25°C)

Characteristics	Symbol	Rating	Unit
VCC Pin Voltage	V _{CC}	V _{SS} - 0.3 to V _{SS} + 25	V
Feedback Pin Voltage	V _{FB}	V _{SS} - 0.3 to V _{CC}	V
ON/OFF Pin Voltage	V _{EN}	V _{SS} - 0.3 to V _{CC} + 0.3	V
Switch Pin Voltage	V _{SW}	V _{SS} - 0.3 to V _{CC} + 0.3	V
Power Dissipation	PD	Internally limited	mW
Storage Temperature Range	T _{ST}	-40 to +150	°C
Operating Temperature Range	T _{OP}	-20 to +125	°C
Operating Supply Voltage	V _{OP}	+3.6 to +23	V
Thermal Resistance from Junction to case	θ _{JC}	25	°C/W
Thermal Resistance from Junction to ambient	θ _{JA}	70	°C/W

Note : θ_{JA} is measured with the PCB copper area(need connect to SW pins) of approximately 1 in²(Multi-layer).

Electrical Characteristics (VIN = 12V, Ta=25°C, unless otherwise specified)

Characteristics	Symbol	Conditions	Min	Typ	Max	Units	
Feedback Voltage	V _{FB}	I _{OUT} =0.1A	0.784	0.8	0.816	V	
Quiescent Current	I _{CCQ}	V _{FB} =1.2V force driver off		3	5	mA	
Feedback Bias Current	I _{FB}	I _{OUT} =0.1A	-	0.1	0.5	uA	
Shutdown Supply Current	I _{SD}	V _{EN} =0V	-	2	10	uA	
Switch Current	I _{SW}		4.0	-	-	A	
Line Regulation	ΔV _{OUT} /V _{OUT}	V _{CC} = 5V~23V, I _{OUT} =0.2A	-	0.6	1.2	%	
Load Regulation	ΔV _{OUT} /V _{OUT}	I _{OUT} = 0.1 to 3A	-	0.2	0.4	%	
Oscillation Frequency	F _{OSC}	SW pin	260	330	400	KHz	
EN Pin Logic input threshold voltage	V _{SH}	High (regulator ON)	2.0	-	-	V	
	V _{SL}	Low (regulator OFF)	-	-	0.8		
EN Pin Input Current	I _{SH}	V _{EN} =2.5V (ON)	-	20	-	uA	
	I _{SL}	V _{EN} =0.3V (OFF)	-	-10	-	uA	
Soft-Start Time	T _{SS}		0.3	4	8	ms	
Internal MOSFET R _{DS(ON)}	R _{DS(ON)}	V _{CC} =5V, V _{FB} =0V	-	90	140	mΩ	
		V _{CC} =12V, V _{FB} =0V	-	60	90		
Efficiency	EFFI	V _{OUT} = 5V	I _{OUT} = 2A	-	92	-	%
			I _{OUT} = 3A	-	91	-	
Thermal shutdown Temp	TSD			125		°C	



Application Circuit

1. MLCC

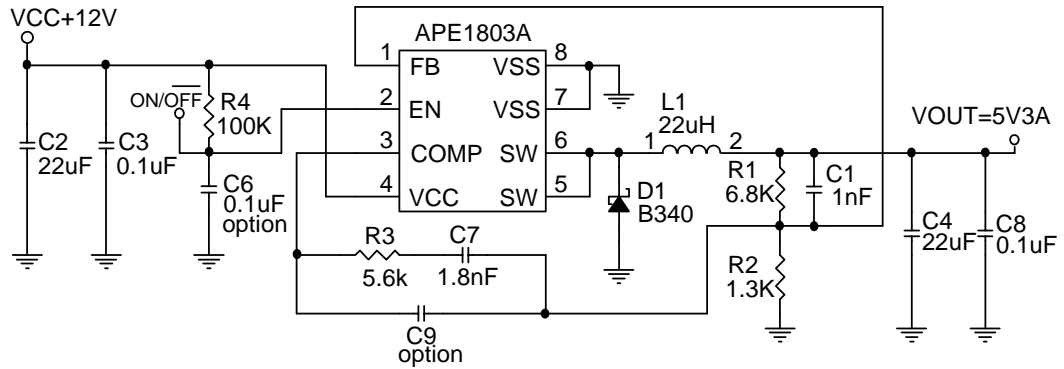

$$V_{OUT} = V_{FB} \times \left(1 + \frac{R_1}{R_2}\right)$$

$V_{FB} = 0.8V$; R_2 suggest $0.8K \sim 3.0K$

2. AL CAP

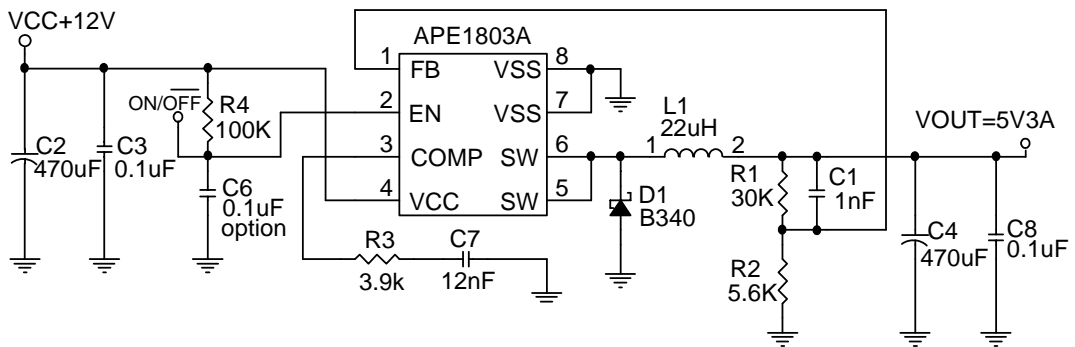

$$V_{OUT} = V_{FB} \times \left(1 + \frac{R_1}{R_2}\right)$$

$V_{FB} = 0.8V$; R_2 suggest $0.8K \sim 6.0K$

L1 recommend value ($V_{IN}=12V, I_{OUT}=3A$)				
V_{OUT}	1.8 V	2.5V	3.3V	5V
L1 Value	12uH	15uH	18uH	22uH

Function Descriptions

PWM Control

The APE1803A consists of DC/DC converters that employ a pulse-width modulation (PWM) system. In converters of the APE1803A, the pulse width varies in a range from 0 to 100%, according to the load current. The ripple voltage produced by the switching can easily be removed through a filter because the switching frequency remains constant. Therefore, these converters provide a low-ripple power over broad ranges of input voltage and load current.

RDS(ON) Current Limiting

The current limit threshold is setting by the internal circuit.

Setting the Output Voltage

Application circuit item shows the basic application circuit with APE1803A adjustable output version. The external resistor sets the output voltage according to the following equation:

$$V_{OUT} = 0.8V \times \left(1 + \frac{R1}{R2} \right)$$

Table 1 Resistor select for output voltage setting

V _{OUT}	R2	R1
5V	1.3K	6.8K
	5.6K	30K
3.3V	1.5K	4.7K
	5.6K	18K
2.5V	2.2K	4.7K
	5.6K	12K
1.8V	1.2K	1.5K
1.5V	2.2K	2.0K

PCB Layout Guide

If you need low T_c & T_j or large PD(Power Dissipation), The dual SW pins(5&6) on the SOP-8 package are internally connected to die pad, The PCB layout should allow for maximum possible copper area at the SW pins.

1. Connect C5 to V_{CC} pin as closely as possible to get good power filter effect.
2. Connect R3 to V_{CC} pin as closely as possible.
3. Connect ground side of the C2 & D1 as closely as possible.



Typical Characteristics

VFB VS VIN

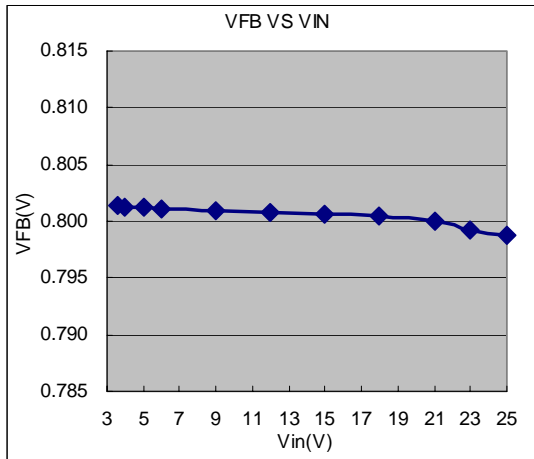

ICCQ VS VIN

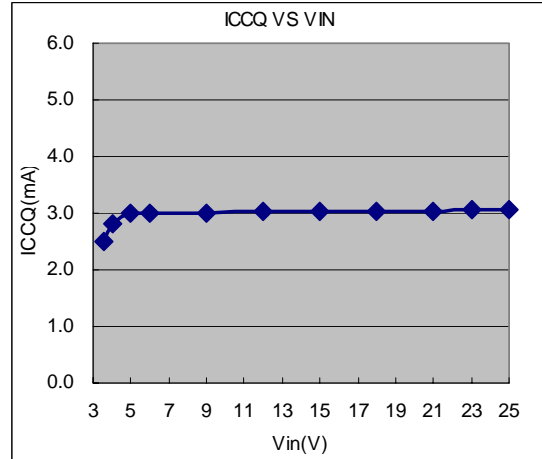

FOSC VS VIN

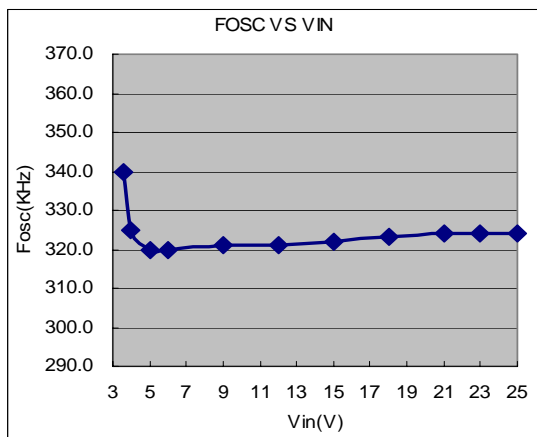

FOSC VS TEMPERATURE

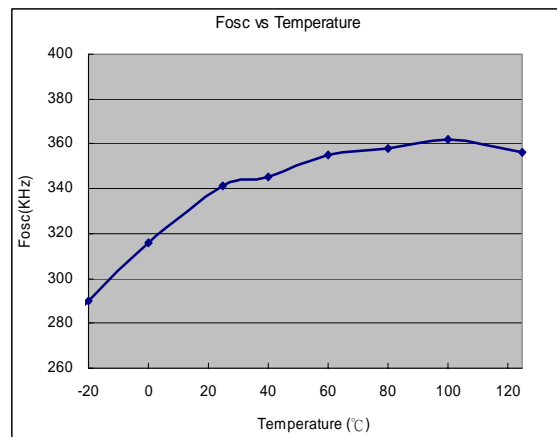

VFB VS TEMPERATURE

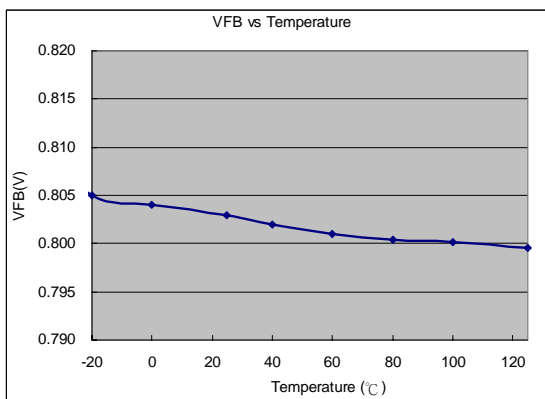

ICCQ VS TEMPERATURE

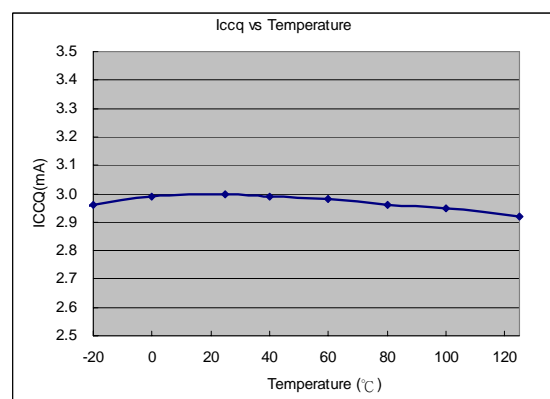



Typical Characteristics (MLCC)

Output Ripple

($V_{IN}=12V, V_{OUT}=3.3V, I_{OUT}=3A$)

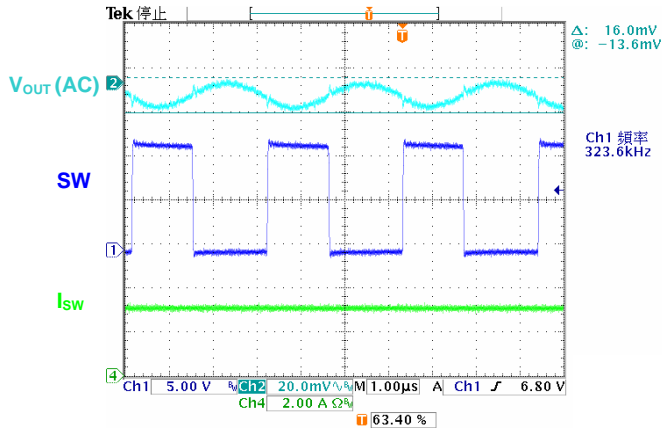

Power on test wave

($V_{IN}=12V, V_{OUT}=5V, I_{OUT}=3A$)

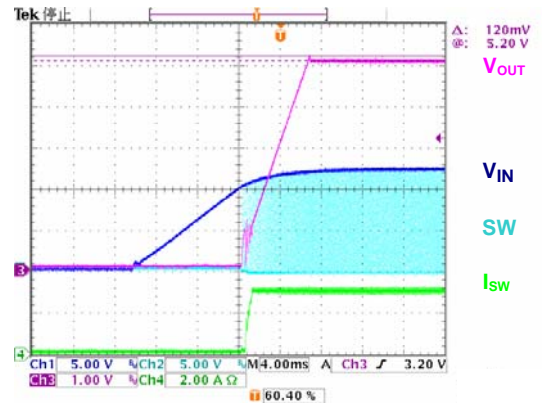

Load Transient Response

($V_{IN}=12V, V_{OUT}=5V, I_{OUT}=0.1\sim 3A$)

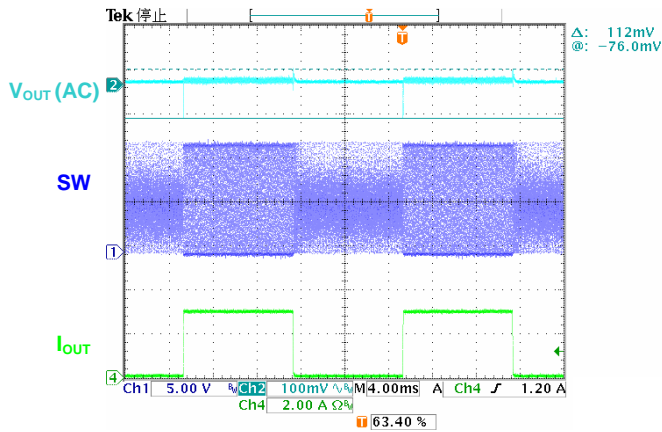

EN on test wave

($V_{IN}=12V, V_{OUT}=5V, I_{OUT}=3A$)

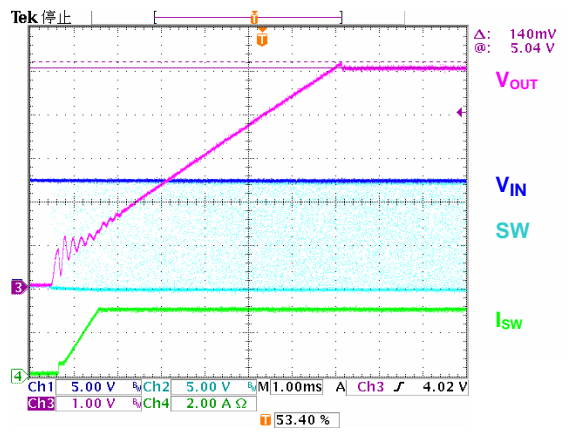

Efficiency

($V_{IN}=12V, V_{OUT}=5V$)

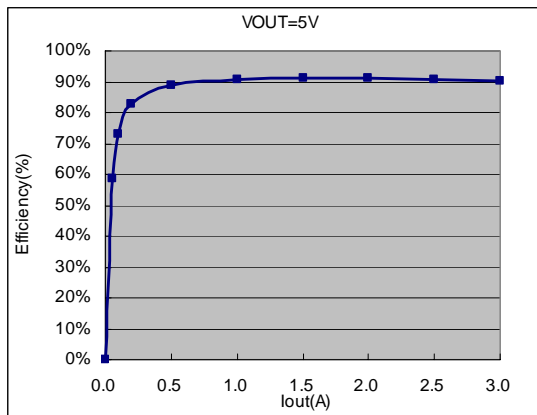

Efficiency

($V_{IN}=12V, V_{OUT}=3.3V$)

