



300mA Low Dropout Linear Regulator with Shutdown

Description

The APE8800A is a low dropout, positive linear regulator with very low quiescent current. The APE8800A can supply 300mA output current with low dropout voltage at about 250mV. The BP pin with a 10nF bypass capacitor can help reduce the output noise level. The shutdown function can provide remote control for the external signal to decide the on/off state of APE8800A. With a logic high level at SHDN pin, the device is in the on state, and vice versa.

The APE8800A regulator is able to operate with output capacitors as small as 1µF for stability. Other than the current limit protection, APE8800A also offers the on chip thermal shutdown feature providing protection against overload or any condition when the ambient temperature exceeds the maximum junction temperature.

The APE8800A offers high precision output voltage of ± 2%. It is available in fixed output voltages including 1.2V, 1.5V, 1.8V, 2.5V, 3.0V, and 3.3V.

The APE8800A is housed in low-profile, space-saving 5-lead SOT-23-5 package.

Pin Assignments

SOT-23-5 Package

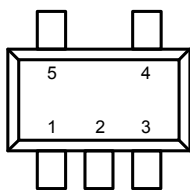

- TOP VIEW
 1. VIN
 2. GND
 3. SHDN
 4. BP
 5. VOUT

Figure 1. Pin Assignment of APE8800A

Features

- Low Dropout Voltage of 250mV at 300mA
- Guaranteed 300mA Output Current
- Very Low Quiescent Current at 30µA
- Max. ± 2% Output Voltage Accuracy
- Needs Only 1µF Capacitor for Stability
- Thermal Shutdown Protection
- Current Limit Protection
- Active Low Shutdown Control
- Low-ESR Ceramic Capacitor for Output Stability
- Tiny package: SOT-23-5
- RoHS Compliant

Applications

- DSC
- Wireless Devices
- LCD Modules
- Battery Power Systems
- Card Readers
- PDA

Ordering Information

APE8800A-

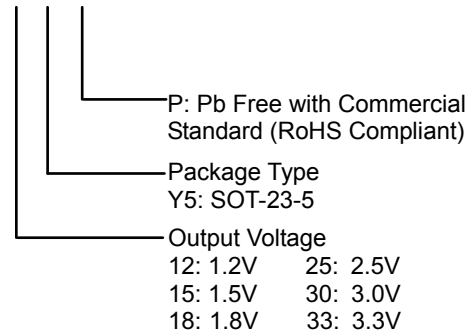

SOT-23-5 Marking

Part Number	Product Code	Part Number	Product Code
APE8800A-12Y5P	Fa	APE8800A-25Y5P	Fd
APE8800A-15Y5P	Fc	APE8800A-30Y5P	Ff
APE8800A-18Y5P	Fb	APE8800A-33Y5P	Fh



Typical Application Circuit

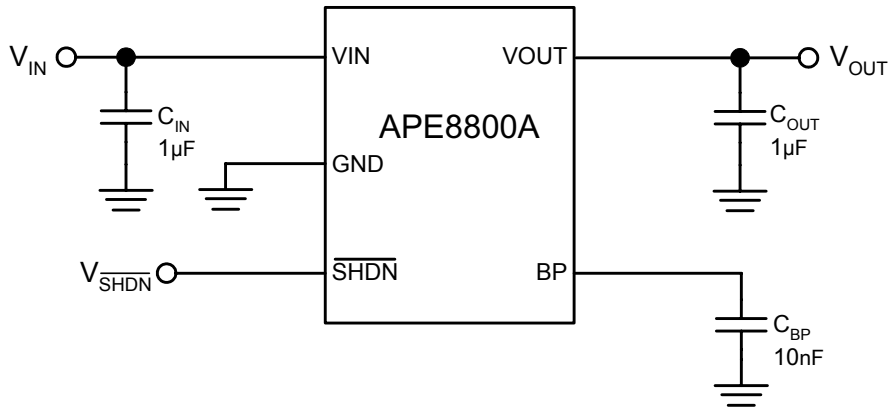

Figure 2. Typical Application Circuit of APE8800A

Note : To prevent oscillation, it is recommended to use minimum 1µF X7R or X5R dielectric capacitors if ceramics are used as input/output capacitors.

Functional Pin Description

Pin Name	Pin Function
VIN	Power is supplied to this device from this pin which is required an input filter capacitor. In general, the input capacitor in the range of 1µF to 10µF is sufficient.
VOUT	The output supplies power to loads. The output capacitor is required to prevent output voltage from oscillation. The APE8800A is stable with an output capacitor 1µF or greater. The larger output capacitor will be required for application with larger load transients. The large output capacitor could reduce output noise, improve stability, and PSRR.
GND	Common ground pin
BP	Reference Noise Bypass (the Bypass Capacitor >= 1nF)
$\overline{\text{SHDN}}$	Chip Enable (Active High)

Block Diagram

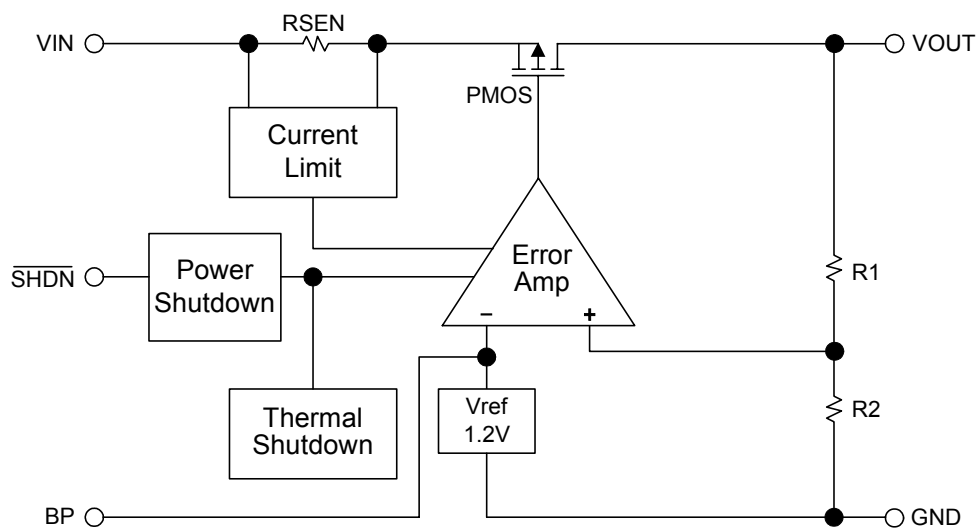

Figure 3. Block Diagram of APE8800A



Absolute Maximum Ratings

- Supply Input Voltage (V_{IN})----- + 6V
- Maximum Junction Temperature (T_J)----- + 150°C
- Power Dissipation SOT-23 (P_D)----- + 0.4W
- Package Thermal Resistance SOT-23 (θ_{JA})----- + 250°C/W
- Storage Temperature Range (T_S)----- - 65 to + 150°C
- Lead Temperature (Soldering, 10 sec.) (T_{LEAD})----- + 260°C

Note : Stresses beyond those listed under “Absolute Maximum Ratings” may cause permanent damage to the device.

Recommended Operating Conditions

- Input Voltage (V_{IN})----- + 2.8 to + 5.5V
- Operating Junction Temperature Range (T_J)----- - 40 to + 125°C
- Ambient Temperature (T_A)----- -40 to 85°C

Electrical Characteristics

($V_{IN}=V_{OUT}+1V$ or $V_{IN}=2.8V$ whichever is greater, \overline{SHDN} pin connected to V_{IN} , $C_{IN}=1\mu F$, $C_{OUT}=1\mu F$, $T_A=25^\circ C$, unless otherwise specified)

Parameter	Symbol	Conditions	Min	Typ	Max	Unit
Current Limit	I_{LIMIT}	$R_{Load}=1\Omega$	300			mA
Quiescent Current	I_Q	$I_O=0mA$		30	50	μA
Standby Current	I_{STBY}	$V_{IN}=2.8\sim 5V$, Output Off			0.1	μA
Output Voltage Accuracy	ΔV_{OUT}	$I_O=1mA$	-2		+2	%
Dropout Voltage (Note 1)	V_{DROP}	$1.5V \leq V_{OUT} \leq 2.0V$		1100		mV
		$2.0V < V_{OUT} \leq 2.8V$		350		
		$2.8V < V_{OUT} \leq 4.5V$		250		
Line Regulation	ΔV_{LINE}	$I_O=1mA$, $V_{IN}=V_{OUT}+1V$ to 5V		1	5	mV
Load Regulation (Note 2)	ΔV_{LOAD}	$I_O=0mA$ to 300mA		6	20	mV
Ripple Rejection	PSRR	$V_{IN}=V_{OUT}+1V$ $f_{RIPPLE} = 120Hz$, $C_{OUT} = 1\mu F$		60		dB
Output Noise	Δn	$C_{BP}=10nF$, $f=1KHz$, $V_{IN}=5V$		0.4		$\frac{\mu V}{\sqrt{Hz}}$
Temperature Coefficient	TC	$I_{OUT} = 1mA$, $V_{IN} = 5V$		50		ppm/°C
Thermal Shutdown Temperature	TSD			160		°C
Thermal Shutdown Hysteresis	ΔTSD			25		°C
Shutdown Pin Current	I_{SHDN}				0.1	μA
Noise Bypass Terminal Voltage	V_{REF}			1.23		V
Shutdown Pin Voltage (ON)	$V_{SHDN(ON)}$		1.4			V
Shutdown Pin Voltage (OFF)	$V_{SHDN(OFF)}$				0.4	V
Shutdown Exit Delay Time	ΔT	$C_{BP}=0.1\mu F$, $C_{OUT}=1\mu F$, $I_{OUT}=30mA$		300		μs

Note 1 : The dropout voltage is defined as $V_{IN}-V_{OUT}$, which is measured when V_{OUT} drops about 100mV.

Note 2 : Regulation is measured at a constant junction temperature by using 40ms current pulse and load regulation in the load range from 0mA to 300mA.



Application Information

The APE8800A is a low dropout linear regulator that could provide 300mA output current at dropout voltage about 250mV. Current limit and on chip thermal shutdown features provide protection against any combination of overload or ambient temperature that could exceed maximum junction temperature.

1. Output and Input Capacitor

The APE8800A regulator is designed to be stable with a wide range of output capacitors. The ESR of the output capacitor affects stability. Larger value of the output capacitor decreases the peak deviations and improves transient response for larger current changes.

The capacitor types (aluminum, ceramic, and tantalum) have different characterizations such as temperature and voltage coefficients. All ceramic capacitors are manufactured with a variety of dielectrics, each with different behavior across temperature and applications. Common dielectrics used are X5R, X7R and Y5V. It is recommended to use 1uF to 10uF X5R or X7R dielectric ceramic capacitors with 30mΩ to 50mΩ ESR range between device outputs and ground for stability. The APE8800A is designed to be stable with low ESR ceramic capacitors and higher values of capacitors and ESR could improve output stability. The ESR of output capacitor is very important because it generates a zero to provide phase lead for loop stability.

There are no requirements for the ESR on the input capacitor, but its voltage and temperature coefficient have to be considered for device application environment.

2. Protection Features

In order to prevent overloading or thermal condition from damaging the device, APE8800A has internal thermal and current limiting functions designed to protect the device. It will rapidly shut off PMOS pass element during overloading or over temperature condition.

3. Thermal Consideration

The power handling capability of the device will be limited by maximum operation junction temperature. The power dissipated by the device will be estimated by $PD = I_{OUT} \times (V_{IN} - V_{OUT})$. The power dissipation should be lower than the maximum power dissipation listed in "Absolute Maximum Ratings" section.

4. Shutdown Operation

The APE8800A is shutdown by pulling the \overline{SHDN} input low, and turned on by driving the \overline{SHDN} high. If this function is not used, the \overline{SHDN} input should be tied to V_{IN} to keep the regulator on at all times (the \overline{SHDN} must not be left floating).



Typical Performance Curves

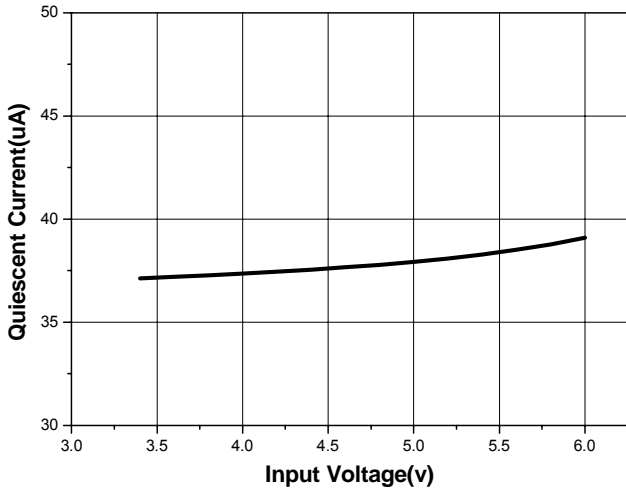

Figure 4. Quiescent Current vs. Input Voltage

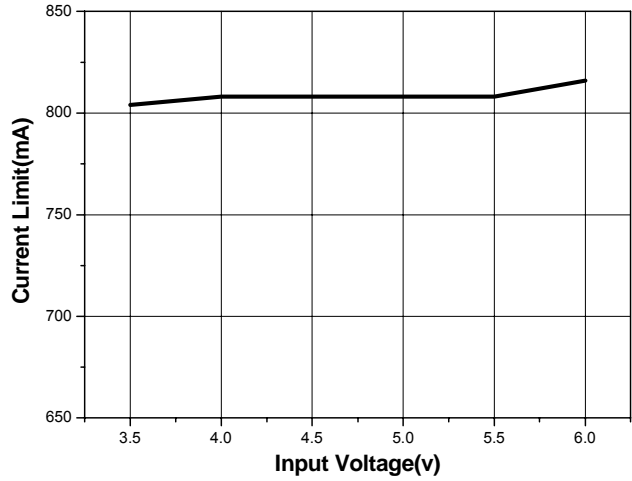

Figure 5. Current limit vs. Input Voltage

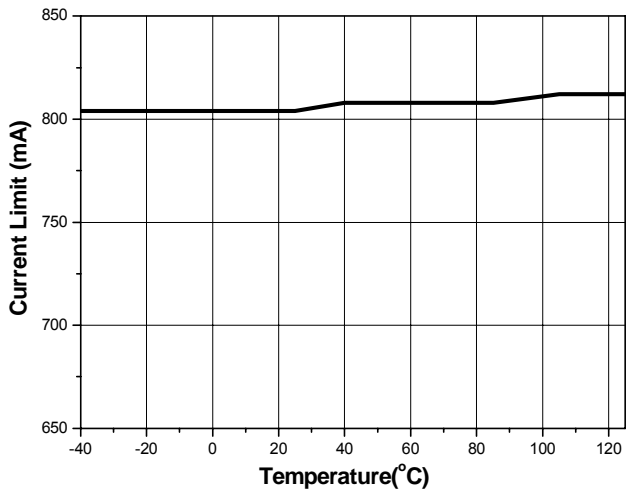

Figure 6. Current limit vs. Temperature

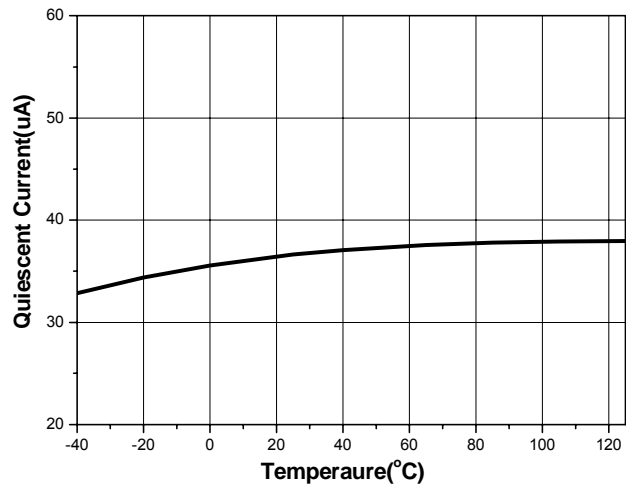

Figure 7. Quiescent Current vs. Temperature

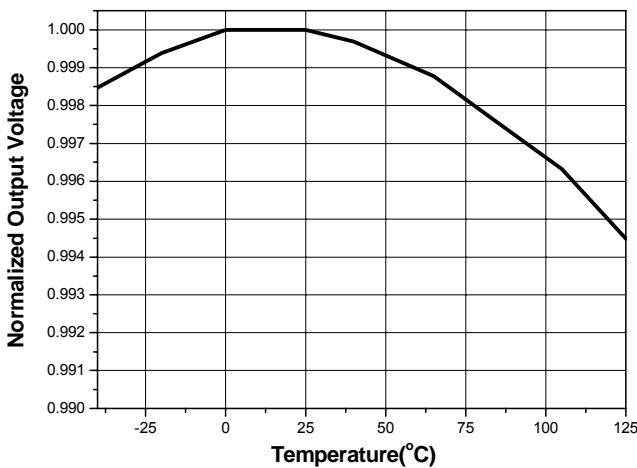

Figure 8. Output Voltage vs. Temperature

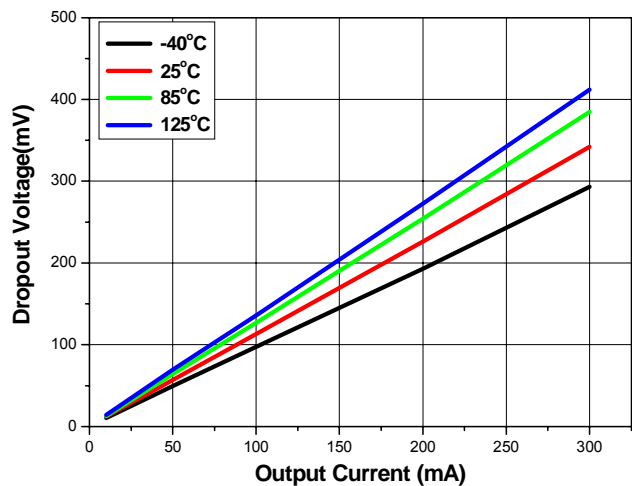

Figure 9. Dropout Voltage vs. Temperature



Typical Performance Curves (Continued)

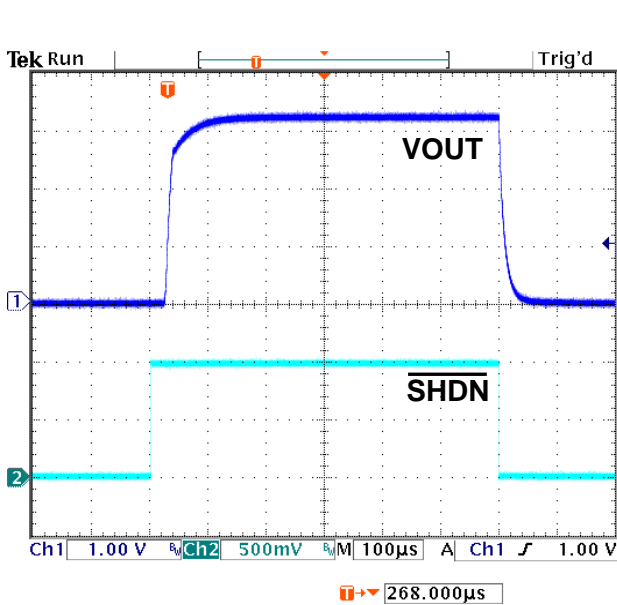

Figure 10. Shutdown Function

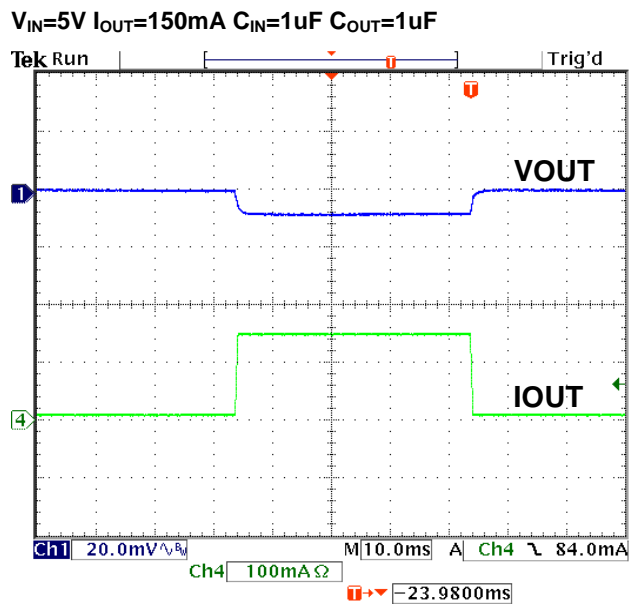

Figure 11. Load Transient Response

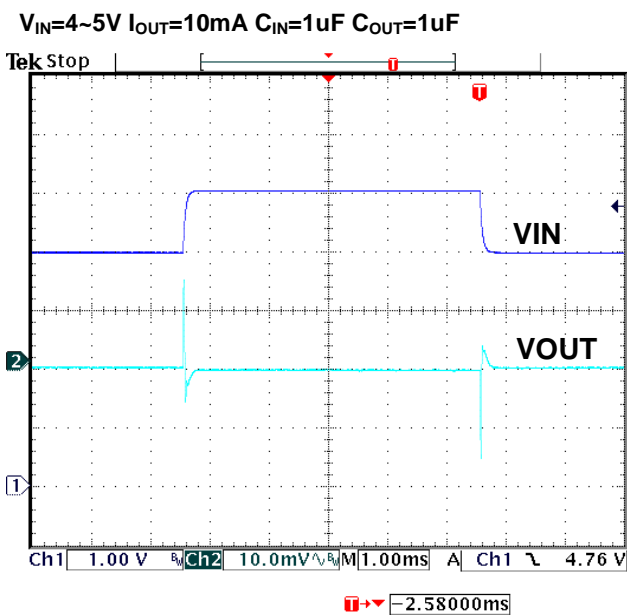

Figure 12. Line Transient Response

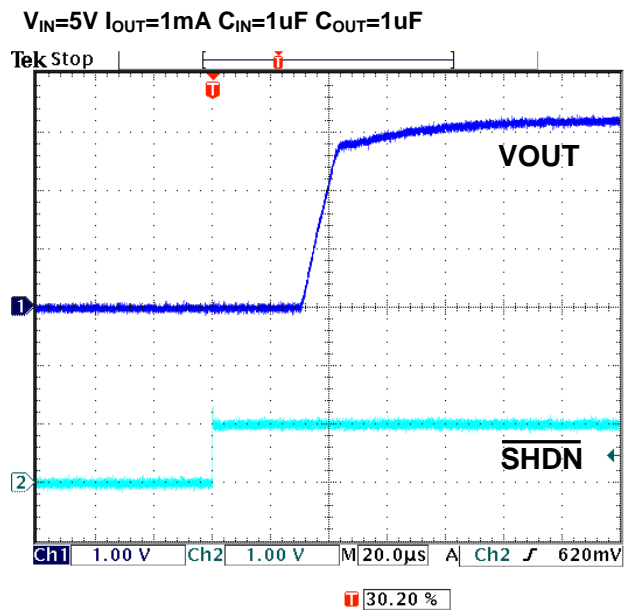
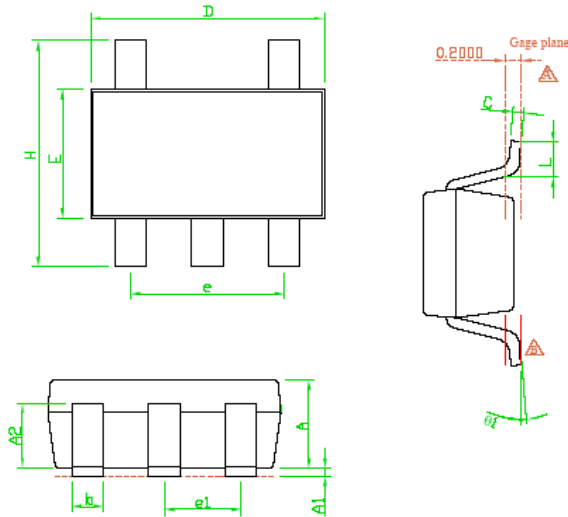

Figure 13. Shutdown Exit Delay Time



Outline Information

SOT-23-5 Package (Unit: mm)



SYMBOLS UNIT	DIMENSION IN MILLIMETER		
	MIN	NOM	MAX
A	1.00	1.10	1.30
A1	0.00	---	0.10
A2	0.70	0.80	0.90
b	0.35	0.40	0.50
C	0.10	0.15	0.25
D	2.70	2.90	3.10
E	1.50	1.60	1.80
e	---	1.90(TYP)	---
H	2.60	2.80	3.00
L	0.37	---	---
$\theta 1$	1°	5°	9°
e1	---	0.95(TYP)	---

Note 1 : Package Body Sizes Exclude Mold Flash Protrusions or Gate Burrs.

Note 2 : Tolerance ± 0.1000 mm(4mil) Unless Otherwise Specified.

Note 3 : Coplanarity : 0.1000 mm

Note 4 : Dimension L Is Measured in Gage plane.

•