

■ General Description

The AME8824 family of positive, linear regulators feature low quiescent current (30µA typ.) with low dropout voltage, making them ideal for battery applications. The space-saving SOT-26 package are attractive for "Pocket" and "Hand Held" applications.

These rugged devices have both Thermal Shutdown, and Current Fold-back to prevent device failure under the "Worst" of operating conditions.

The SOT-26 version also features a "Power Good" detector, which pulls low when the output is out of regulation.

The AME8824 is stable with an output capacitance of 2.2µF or greater.

■ Features

- Very Low Dropout Voltage
- Guaranteed 300mA Output
- Typical accuracy within 2%
- 30µA Quiescent Current
- Over-Temperature Shutdown
- Current Limiting
- Short Circuit Current Fold-back
- Power Good Detector (6 pin version only)
- Power-Saving Shutdown Mode
- Space-Saving SOT-26
- Adjustable Output Voltages
- Low Temperature Coefficient
- All AME's Lead Free Products Meet RoHS Standards

■ Applications

- Instrumentation
- Portable Electronics
- Wireless Devices
- Cordless Phones
- PC Peripherals
- Battery Powered Widgets
- Electronic Scales

■ Functional Block Diagram

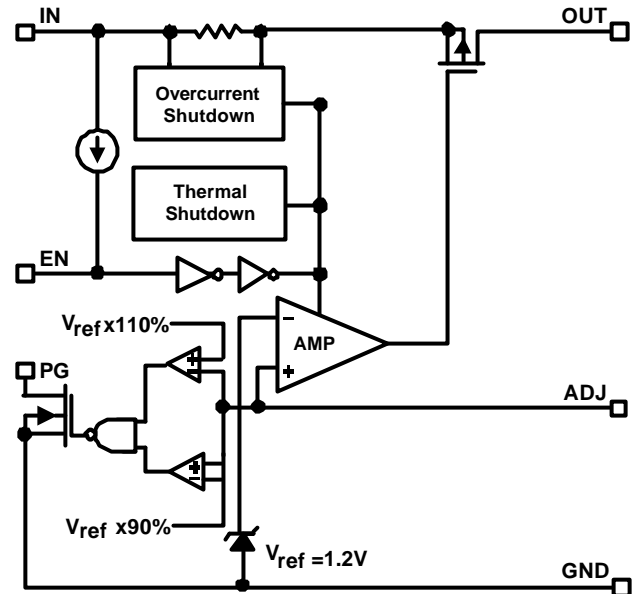

■ Typical Application

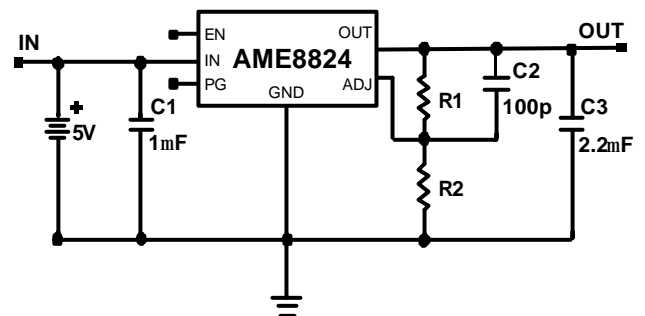

$$V_{OUT} = 1.2 (R1 + R2) / R2$$

C2 is unnecessary when R1 or R2 < 20K
PG pin is only available in the SOT-26 package option

■ Advanced Application

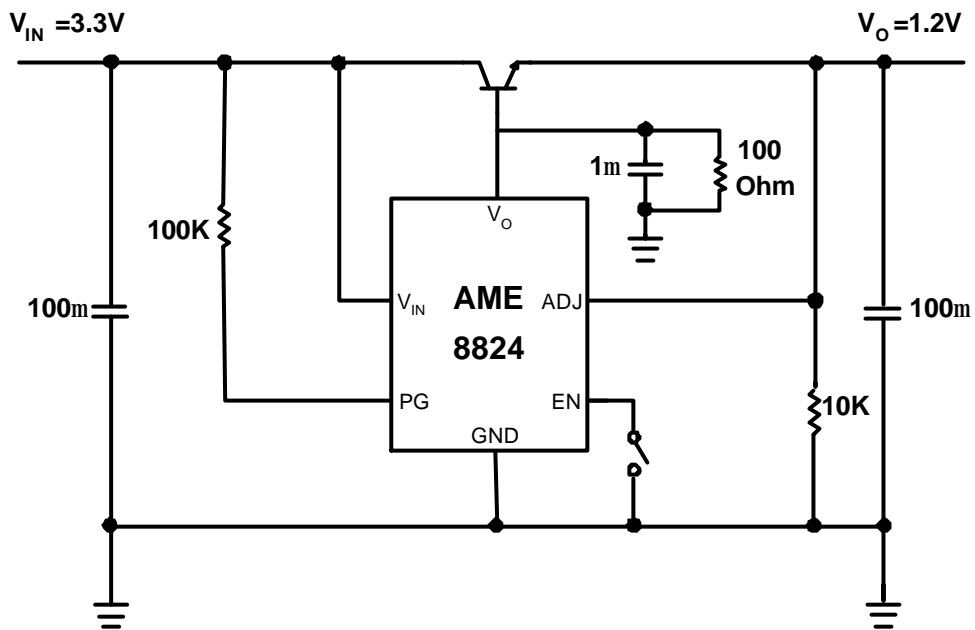



Pin Configuration

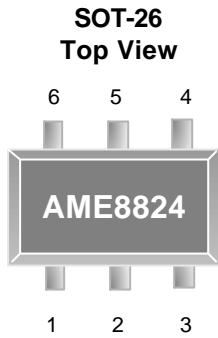

AME8824

1. V_{IN}
2. GND
3. EN
4. PG
5. ADJ
6. V_{OUT}

* Die Attach:
Non-Conductive Epoxy

Ordering Information

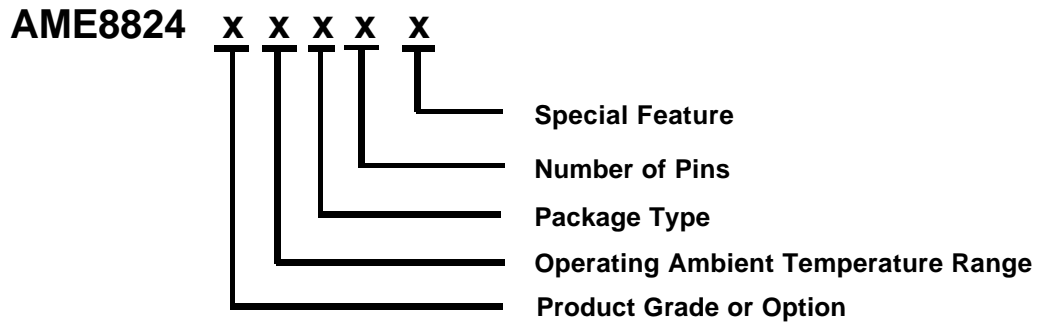

Product Grade or Option	Operating Ambient Temperature Range	Package Type	Number of Pins	Special Feature
A: ADJ	E: -40°C to 85°C	E: SOT-2X	Y: 6	L: Low Profile Y: Lead Free & Low Profile Z: Lead Free

Ordering Information

Part Number	Marking*	Output Voltage	Package	Operating Ambient Temperature Range
AME8824AEEY	AUEww	ADJ	SOT-26	- 40°C to + 85°C
AME8824AEEYL	AUEww	ADJ	TSOT-26	- 40°C to + 85°C
AME8824AEEYY	AUEww	ADJ	TSOT-26	- 40°C to + 85°C
AME8824AEEYZ	AUEww	ADJ	SOT-26	- 40°C to + 85°C

ww: represents the date code and pls refer to Date Code Rule before Package Dimension.

* A line on top of the first character represents lead free plating such as $\overline{A}UEww$

Please consult AME sales office or authorized Rep./Distributor for the availability of output voltage and package type.



■ Absolute Maximum Ratings

Parameter	Maximum	Unit
Input Voltage	8	V
Output Current	$P_D / (V_{IN} - V_O)$	mA
Input, Output Voltage	GND - 0.3 to $V_{IN} + 0.3$	V
ESD Classification	B*	

Caution: Stress above the listed absolute maximum rating may cause permanent damage to the device.

*HBM B:2000V~3999V

■ Recommended Operating Conditions

Parameter	Symbol	Rating	Unit
Ambient Temperature Range	T_A	- 40 to + 85	°C
Junction Temperature Range	T_J	- 40 to + 125	°C

■ Thermal Information

Parameter	Package	Die Attach	Symbol	Maximum	Unit
Thermal Resistance* (Junction to Case)	SOT-26	Non-Conductive Epoxy	θ_{JC}	140	°C / W
Thermal Resistance (Junction to Ambient)			θ_{JA}	280	
Internal Power Dissipation			P_D	400	mW
Maximum Junction Temperature				150	°C
Solder Iron (10 Sec)**				350	°C

* Measure θ_{JC} on center of moulding compound if IC has no tab.

** MIL-STD-202G 210F

■ Electrical Specifications

TA = 25°C, V_{IN}=5V unless otherwise noted

Parameter	Symbol	Test Condition	Min	Typ	Max	Units
Input Voltage	V _{IN}		Note 1		7	V
Output Voltage	V _O	I _O =1mA	-3		3	%
Dropout Voltage	V _{DROPOUT}	I _O =300mA V _O =V _{ONOM} -2.0%	1.2V<=V _{O(NOM)} <=2.0V		1300	mV
			2.0V<V _{O(NOM)} <=2.8V		400	
			2.8V<V _{O(NOM)} <3.8V		300	
Output Current	I _O	V _O >1.2V	300			mA
Current Limit	I _{LIM}	V _O >1.2V	300	450		mA
Short Circuit Current	I _{SC}	V _O <0.8V		150	300	mA
Quiescent Current	I _Q	I _O =0mA		30	50	μA
Ground Pin Current	I _{GND}	I _O =1mA to 300mA		35		μA
Line Regulation	REG _{LINE}	I _O =5mA V _{IN} =V _O +1 to V _O +2	V _O < 2.0V		0.15	%
			V _O >= 2.0V		0.02	0.1
Load Regulation	REG _{LOAD}	I _O =1mA to 300mA		0.2	1	%
Over Temperature Shutdown	OTS			150		°C
Over Temperature Hysteresis	OTH			30		°C
V _O Temperature Coefficient	TC			30		ppm/°C
Power Supply Rejection	PSRR	I _O =100mA C _O =2.2μF	f=1kHz		50	dB
			f=10kHz		20	
			f=100kHz		15	
Output Voltage Noise	e _N	f=10Hz to 100kHz I _O =10mA, C _{BYP} =0μF			30	μVrms
ADJ Input Bias Current	I _{ADJ}			1		μA
ADJ Reference Voltage	V _{REF}		1.176	1.2	1.224	V
EN Input Threshold	V _{EH}	V _{IN} =2.7V to 7V	2.0		V _{in}	V
	V _{EL}	V _{IN} =2.7V to 7V	0		0.4	V
EN Input Bias Current	I _{EH}	V _{EN} =V _{IN} , V _{IN} =2.7V to 7V			0.1	μA
	I _{EL}	V _{EN} =0V, V _{IN} =2.7V to 7V			0.5	μA
Shutdown Supply Current	I _{SD}	V _{IN} =5V, V _O =0V, V _{EN} <V _{EL}		0.5	1	μA
Shutdown Output Voltage	V _{O,SD}	I _O =35μA, V _{EN} <V _{EL}	0		0.1	V
Output Under Voltage	V _{UV}				85	%V _{O(NOM)}
Output Over Voltage	V _{OV}		115			%V _{O(NOM)}
PG Leakage Current	I _{LC}	V _{PG} =7V			1	μA
PG Voltage Rating	V _{PG}	V _O in regulation			7	V
PG Voltage Low	V _{OL}	I _{SINK} =0.4mA			0.4	V

Note1: V_{IN(min)}=V_{OUT}+V_{DROPOUT}



Ground Current vs. Input Voltage

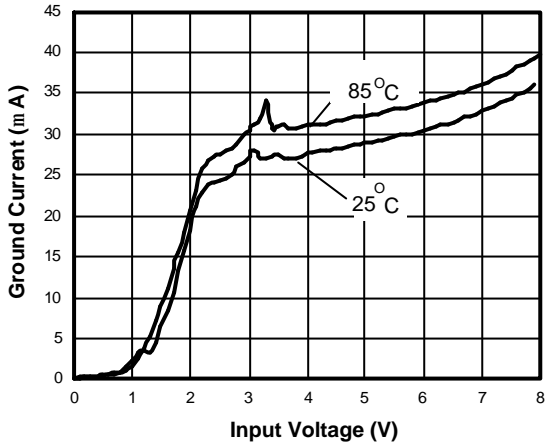

Load Step (1mA-300mA)

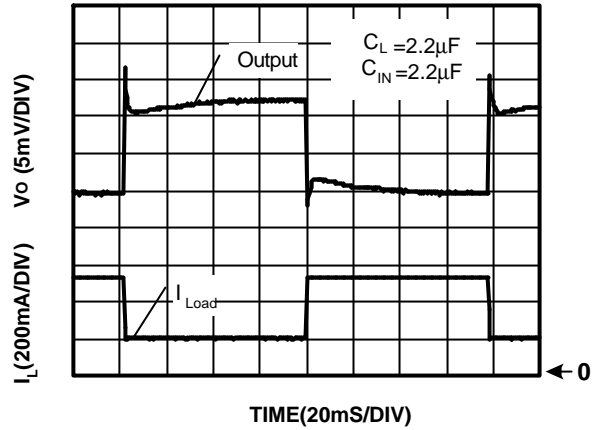

Power Supply Rejection Ratio

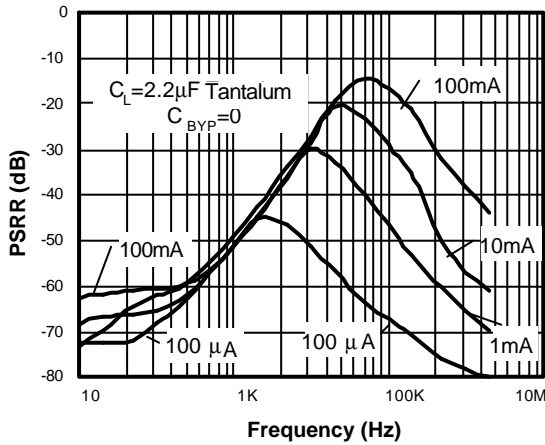

Chip Enable Transient Response

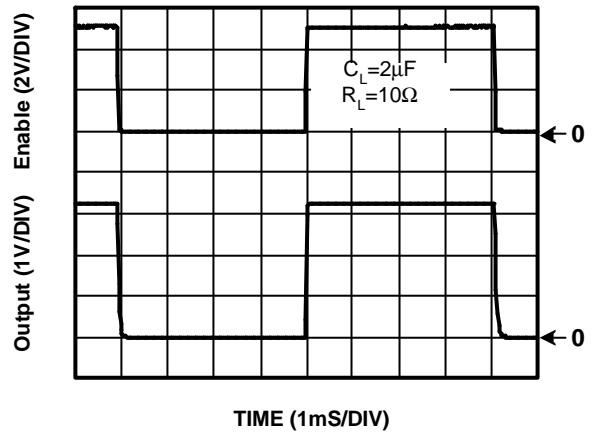

Drop Out Voltage vs. Output Voltage

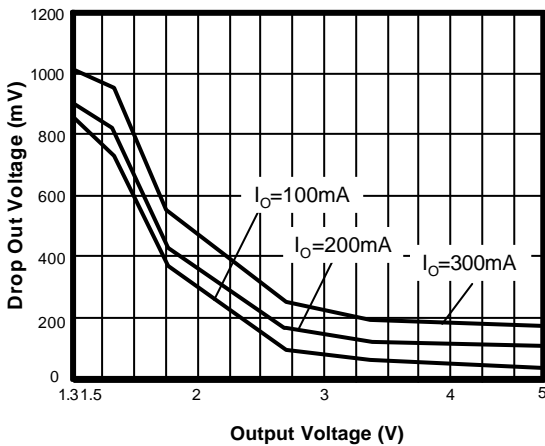

Drop Out Voltage vs. Load Current

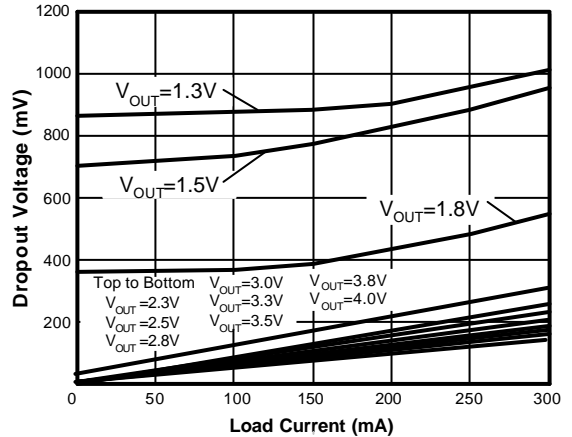



Noise Measurement

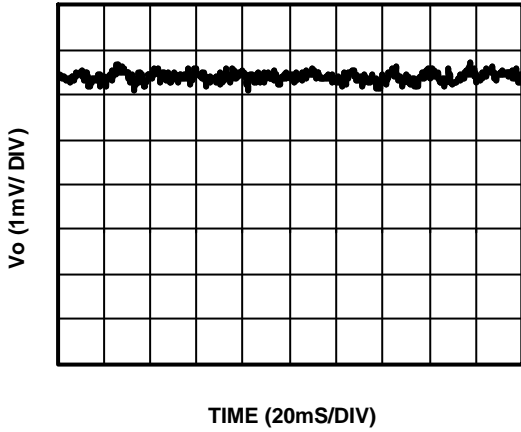

Safe Operating Area

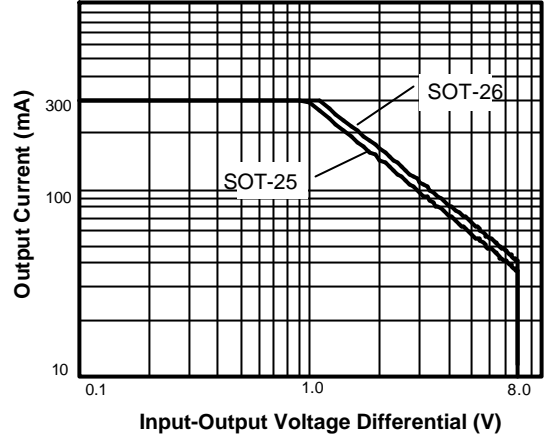

Short Circuit Response

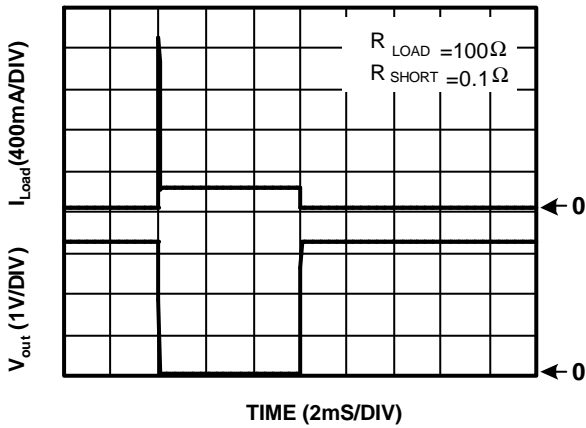

Overtemperature Shutdown

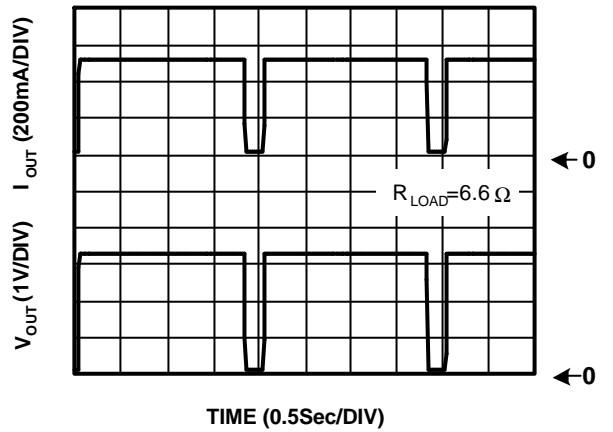

Current Limit Response

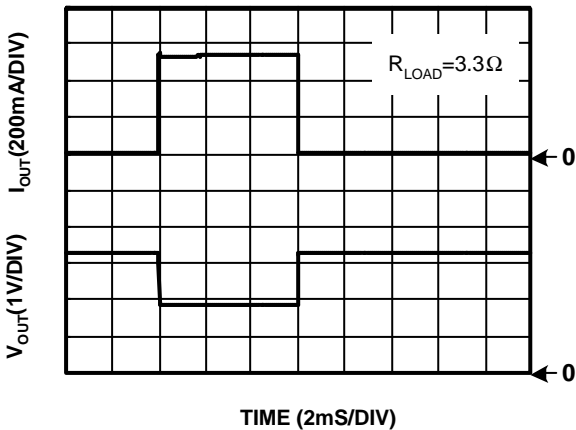

Line Transient Response

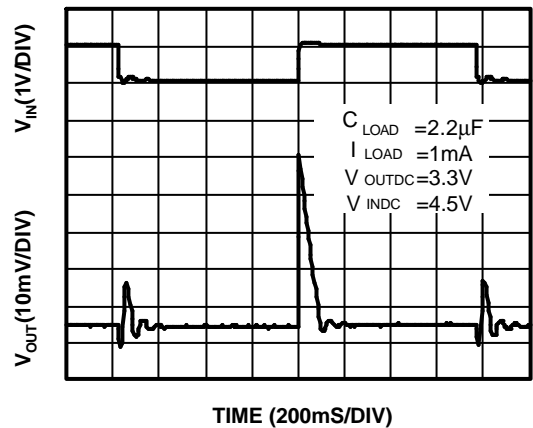

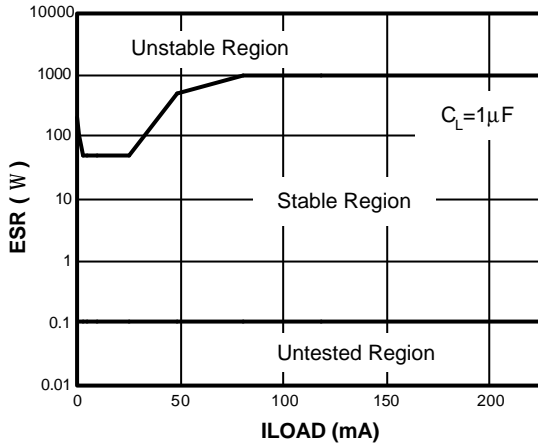
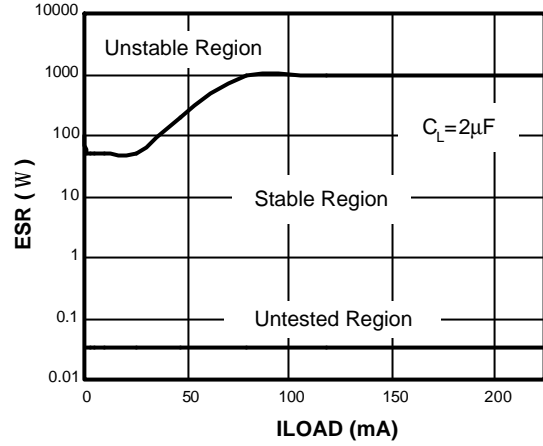
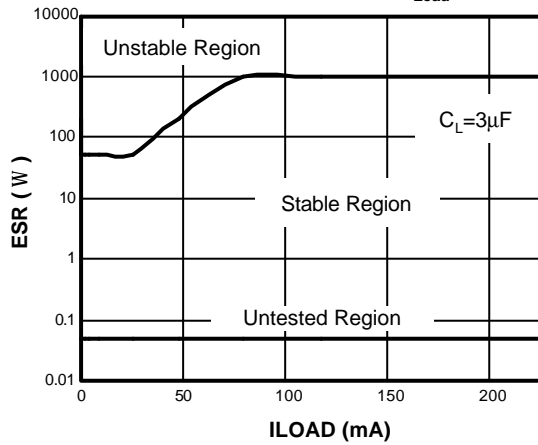
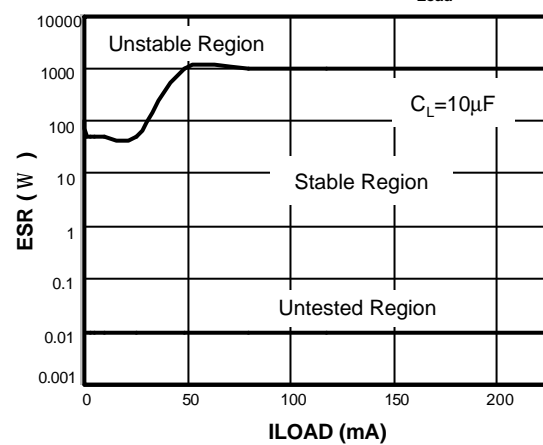
Stability vs. ESR vs. I_{Load}

Stability vs. ESR vs. I_{Load}

Stability vs. ESR vs. I_{Load}

Stability vs. ESR vs. I_{Load}

External Resistor Divider Table

R1 (K Ohm)	1	2	5	10	20	50	100	200	500	1000
Vout	$R2(K\ Ohm)=(1.2*R1(K\ Ohm))/(Vout-1.2)$									
1.25	24.00	48.00	120.00	240.00	480.00	1200.00				
1.30	12.00	24.00	60.00	120.00	240.00	600.00				
1.35	8.00	16.00	40.00	80.00	160.00	400.00				
1.40	6.00	12.00	30.00	60.00	120.00	300.00				
1.45	4.80	9.60	24.00	48.00	96.00	240.00	480.00			
1.50	4.00	8.00	20.00	40.00	80.00	200.00	400.00	800.00		
1.55	3.43	6.86	17.14	34.29	68.57	171.43	342.86	685.71		
1.60	3.00	6.00	15.00	30.00	60.00	150.00	300.00	600.00		
1.65	2.67	5.33	13.33	26.67	53.33	133.33	266.67	533.33		
1.70	2.40	4.80	12.00	24.00	48.00	120.00	240.00	480.00		
1.75	2.18	4.36	10.91	21.82	43.64	109.09	218.18	436.36		
1.80	2.00	4.00	10.00	20.00	40.00	100.00	200.00	400.00		
1.85	1.85	3.69	9.23	18.46	36.92	92.31	184.62	369.23		
1.90	1.71	3.43	8.57	17.14	34.29	85.71	171.43	342.86		
1.95	1.60	3.20	8.00	16.00	32.00	80.00	160.00	320.00	800.00	
2.00	1.50	3.00	7.50	15.00	30.00	75.00	150.00	300.00	750.00	
2.05	1.41	2.82	7.06	14.12	28.24	70.59	141.18	282.35	705.88	
2.10	1.33	2.67	6.67	13.33	26.67	66.67	133.33	266.67	666.67	
2.15	1.26	2.53	6.32	12.63	25.26	63.16	126.32	252.63	631.58	
2.20	1.20	2.40	6.00	12.00	24.00	60.00	120.00	240.00	600.00	
2.25	1.14	2.29	5.71	11.43	22.86	57.14	114.29	228.57	571.43	
2.30	1.09	2.18	5.45	10.91	21.82	54.55	109.09	218.18	545.45	
2.35	1.04	2.09	5.22	10.43	20.87	52.17	104.35	208.70	521.74	
2.40	1.00	2.00	5.00	10.00	20.00	50.00	100.00	200.00	500.00	
2.45	0.96	1.92	4.80	9.60	19.20	48.00	96.00	192.00	480.00	
2.50	0.92	1.85	4.62	9.23	18.46	46.15	92.31	184.62	461.54	
2.55	0.89	1.78	4.44	8.89	17.78	44.44	88.89	177.78	444.44	
2.60	0.86	1.71	4.29	8.57	17.14	42.86	85.71	171.43	428.57	857.14
2.65	0.83	1.66	4.14	8.28	16.55	41.38	82.76	165.52	413.79	827.59
2.70	0.80	1.60	4.00	8.00	16.00	40.00	80.00	160.00	400.00	800.00
2.75	0.77	1.55	3.87	7.74	15.48	38.71	77.42	154.84	387.10	774.19
2.80	0.75	1.50	3.75	7.50	15.00	37.50	75.00	150.00	375.00	750.00
2.85	0.73	1.45	3.64	7.27	14.55	36.36	72.73	145.45	363.64	727.27
2.90	0.71	1.41	3.53	7.06	14.12	35.29	70.59	141.18	352.94	705.88
2.95	0.69	1.37	3.43	6.86	13.71	34.29	68.57	137.14	342.86	685.71
3.00	0.67	1.33	3.33	6.67	13.33	33.33	66.67	133.33	333.33	666.67
3.05	0.65	1.30	3.24	6.49	12.97	32.43	64.86	129.73	324.32	648.65
3.10	0.63	1.26	3.16	6.32	12.63	31.58	63.16	126.32	315.79	631.58



External Resistor Divider Table

R1 (K Ohm)	1	2	5	10	20	50	100	200	500	1000
Vout	$R2(K\ Ohm)=(1.2 \cdot R1(K\ Ohm))/(Vout-1.2)$									
3.15	0.62	1.23	3.08	6.15	12.31	30.77	61.54	123.08	307.69	615.38
3.20	0.60	1.20	3.00	6.00	12.00	30.00	60.00	120.00	300.00	600.00
3.25	0.59	1.17	2.93	5.85	11.71	29.27	58.54	117.07	292.68	585.37
3.30	0.57	1.14	2.86	5.71	11.43	28.57	57.14	114.29	285.71	571.43
3.35	0.56	1.12	2.79	5.58	11.16	27.91	55.81	111.63	279.07	558.14
3.40	0.55	1.09	2.73	5.45	10.91	27.27	54.55	109.09	272.73	545.45
3.45	0.53	1.07	2.67	5.33	10.67	26.67	53.33	106.67	266.67	533.33
3.50	0.52	1.04	2.61	5.22	10.43	26.09	52.17	104.35	260.87	521.74
3.55	0.51	1.02	2.55	5.11	10.21	25.53	51.06	102.13	255.32	510.64
3.60	0.50	1.00	2.50	5.00	10.00	25.00	50.00	100.00	250.00	500.00
3.65	0.49	0.98	2.45	4.90	9.80	24.49	48.98	97.96	244.90	489.80
3.70	0.48	0.96	2.40	4.80	9.60	24.00	48.00	96.00	240.00	480.00
3.75	0.47	0.94	2.35	4.71	9.41	23.53	47.06	94.12	235.29	470.59
3.80	0.46	0.92	2.31	4.62	9.23	23.08	46.15	92.31	230.77	461.54
3.85	0.45	0.91	2.26	4.53	9.06	22.64	45.28	90.57	226.42	452.83
3.90	0.44	0.89	2.22	4.44	8.89	22.22	44.44	88.89	222.22	444.44
3.95	0.44	0.87	2.18	4.36	8.73	21.82	43.64	87.27	218.18	436.36
4.00	0.43	0.86	2.14	4.29	8.57	21.43	42.86	85.71	214.29	428.57
4.05	0.42	0.84	2.11	4.21	8.42	21.05	42.11	84.21	210.53	421.05
4.10	0.41	0.83	2.07	4.14	8.28	20.69	41.38	82.76	206.90	413.79
4.15	0.41	0.81	2.03	4.07	8.14	20.34	40.68	81.36	203.39	406.78
4.20	0.40	0.80	2.00	4.00	8.00	20.00	40.00	80.00	200.00	400.00
4.25	0.39	0.79	1.97	3.93	7.87	19.67	39.34	78.69	196.72	393.44
4.30	0.39	0.77	1.94	3.87	7.74	19.35	38.71	77.42	193.55	387.10
4.35	0.38	0.76	1.90	3.81	7.62	19.05	38.10	76.19	190.48	380.95
4.40	0.37	0.75	1.87	3.75	7.50	18.75	37.50	75.00	187.50	375.00
4.45	0.37	0.74	1.85	3.69	7.38	18.46	36.92	73.85	184.62	369.23
4.50	0.36	0.73	1.82	3.64	7.27	18.18	36.36	72.73	181.82	363.64
4.55	0.36	0.72	1.79	3.58	7.16	17.91	35.82	71.64	179.10	358.21
4.60	0.35	0.71	1.76	3.53	7.06	17.65	35.29	70.59	176.47	352.94
4.65	0.35	0.70	1.74	3.48	6.96	17.39	34.78	69.57	173.91	347.83
4.70	0.34	0.69	1.71	3.43	6.86	17.14	34.29	68.57	171.43	342.86
4.75	0.34	0.68	1.69	3.38	6.76	16.90	33.80	67.61	169.01	338.03
4.80	0.33	0.67	1.67	3.33	6.67	16.67	33.33	66.67	166.67	333.33
4.85	0.33	0.66	1.64	3.29	6.58	16.44	32.88	65.75	164.38	328.77
4.90	0.32	0.65	1.62	3.24	6.49	16.22	32.43	64.86	162.16	324.32
4.95	0.32	0.64	1.60	3.20	6.40	16.00	32.00	64.00	160.00	320.00
5.00	0.32	0.63	1.58	3.16	6.32	15.79	31.58	63.16	157.89	315.79

Note: Small Load (greater than 2mA) is necessary as R1 or R2 is larger than 50 Kohm. Otherwise, output voltage probably cannot be pulled down to 0V on disable mode.



■ Date Code Rule

Marking			Date Code		Year
A	A	A	W	W	xxx0
A	A	A	W	<u>W</u>	xxx1
A	A	A	<u>W</u>	W	xxx2
A	A	A	<u>W</u>	<u>W</u>	xxx3
A	A	<u>A</u>	W	W	xxx4
A	A	<u>A</u>	W	<u>W</u>	xxx5
A	A	<u>A</u>	<u>W</u>	W	xxx6
A	A	<u>A</u>	<u>W</u>	<u>W</u>	xxx7
A	<u>A</u>	A	W	W	xxx8
A	<u>A</u>	A	W	<u>W</u>	xxx9

■ Tape and Reel Dimension

SOT-26

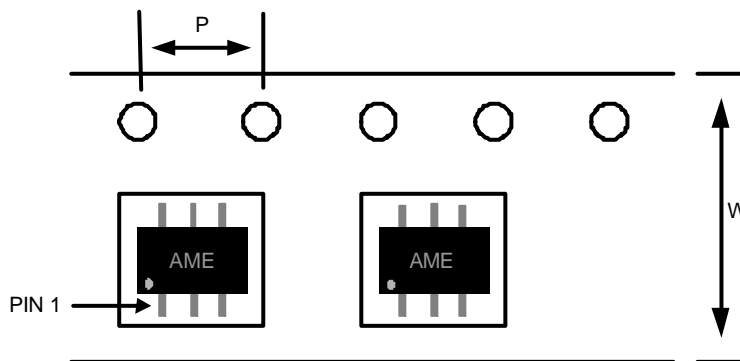

Package	Carrier Width (W)	Pitch (P)	Part Per Full Reel	Reel Size
SOT-26	8.0±0.1 mm	4.0±0.1 mm	3000pcs	180±1 mm

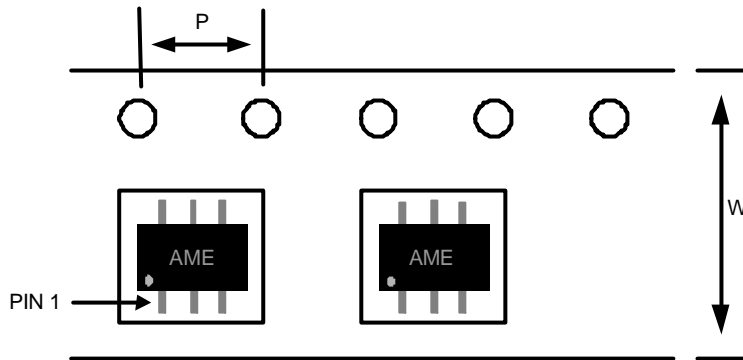
■ Tape and Reel Dimension
TSOT-26

Carrier Tape, Number of Components Per Reel and Reel Size

Package	Carrier Width (W)	Pitch (P)	Part Per Full Reel	Reel Size
TSOT-26	8.0±0.1 mm	4.0±0.1 mm	3000pcs	180±1 mm

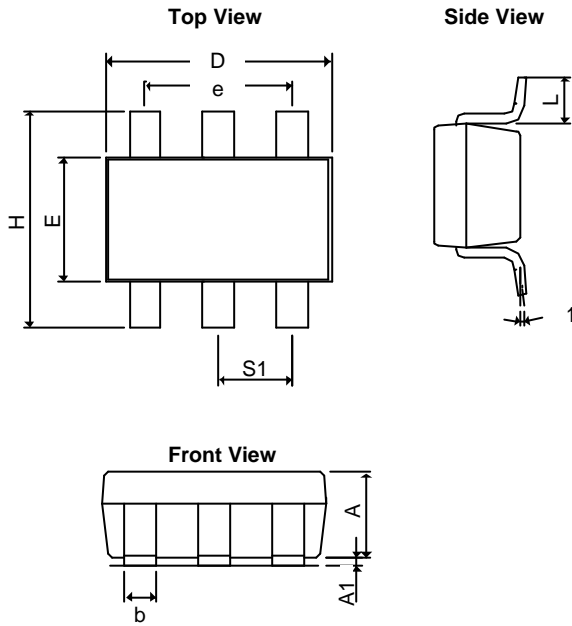

■ Package Dimension

SOT-26



SYMBOLS	MILLIMETERS		INCHES	
	MIN	MAX	MIN	MAX
A	1.20REF		0.0472REF	
A ₁	0.00	0.15	0.0000	0.0059
b	0.30	0.55	0.0118	0.0217
D	2.70	3.10	0.1063	0.1220
E	1.40	1.80	0.0551	0.0709
e	1.90 BSC		0.0748 BSC	
H	2.60	3.00	0.10236	0.11811
L	0.37REF		0.0146REF	
q1	0°	10°	0°	10°
S ₁	0.95REF		0.0374REF	

TSOT-26

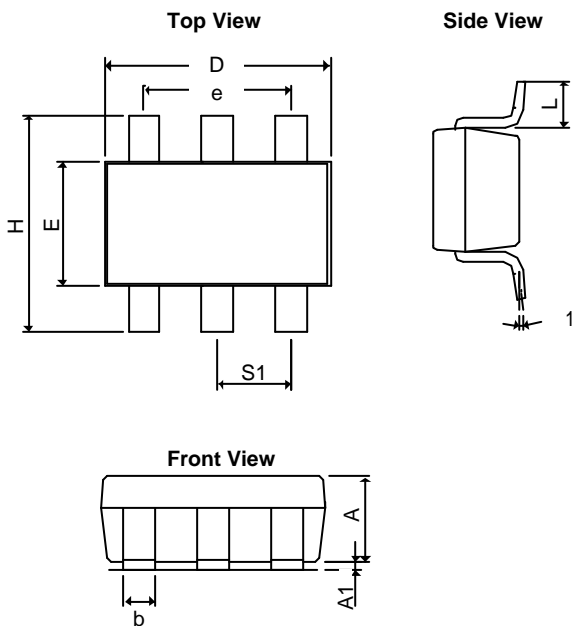

SYMBOLS	MILLIMETERS		INCHES	
	MIN	MAX	MIN	MAX
A+A ₁	0.90	1.25	0.0354	0.0492
b	0.30	0.50	0.0118	0.0197
D	2.70	3.10	0.1063	0.1220
E	1.40	1.80	0.0551	0.0709
e	1.90 BSC		0.07480 BSC	
H	2.40	3.00	0.09449	0.11811
L	0.35BSC		0.0138BSC	
q1	0°	10°	0°	10°
S ₁	0.95BSC		0.0374BSC	



www.ame.com.tw
E-Mail: sales@ame.com.tw

Life Support Policy:

These products of AME, Inc. are not authorized for use as critical components in life-support devices or systems, without the express written approval of the president of AME, Inc.

AME, Inc. reserves the right to make changes in the circuitry and specifications of its devices and advises its customers to obtain the latest version of relevant information.

©AME, Inc. , March 2006

Document: 2006/2095-DS8824-D.01

Corporate Headquarter
AME, Inc.

2F, 302 Rui-Guang Road, Nei-Hu District
Taipei 114, Taiwan.

Tel: 886 2 2627-8687

Fax: 886 2 2659-2989

U.S.A.(Subsidiary)
Analog Microelectronics, Inc.

3100 De La Cruz Blvd., Suite 201
Santa Clara, CA. 95054-2046

Tel : (408) 988-2388

Fax: (408) 988-2489