

## ■ General Description

The AME8810 of positive, linear regulators feature low quiescent current (30 $\mu$ A typ.) with low dropout voltage, making them ideal for battery applications. The space-saving SOT-223 package is attractive for "Pocket" and "Hand Held" applications.

These rugged devices have both Thermal Shutdown, and Current Fold-back to prevent device failure under the "Worst" of operating conditions.

The AME8810 is stable with an output capacitance of 2.2 $\mu$ F or greater.

## ■ Features

- Very Low Dropout Voltage
- Guaranteed 600mA Output
- Accurate to within 1.5%
- 30 $\mu$ A Quiescent Current
- Over-Temperature Shutdown
- Current Limiting
- Short Circuit Current Fold-back
- Space-Saving SOT-223
- Factory Pre-set Output Voltages
- Low Temperature Coefficient
- All AME's Lead Free Products Meet RoHS Standards

## ■ Applications

- Instrumentation
- Portable Electronics
- Wireless Devices
- Cordless Phones
- PC Peripherals
- Battery Powered Widgets
- Electronic Scales

## ■ Functional Block Diagram

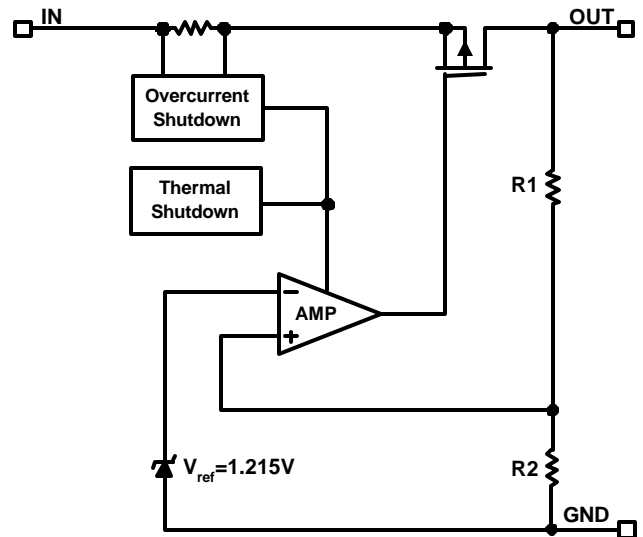

## ■ Typical Application

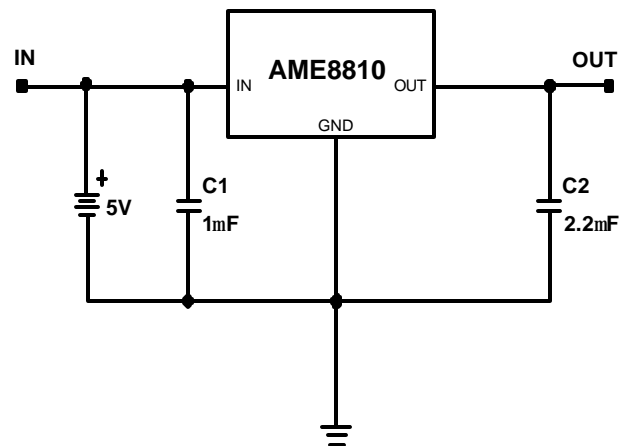

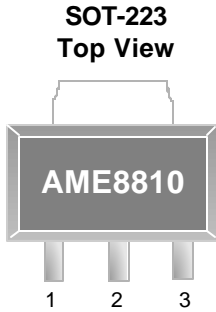
**■ Pin Configuration**

**AME8810**

1. GND
2.  $V_{OUT}$
3.  $V_{IN}$

is the sole product of AME8810 family

Pls contact Sales Department if any other package or pin configuration is required.

\* **Die Attach:**

**Non-Conductive Epoxy**

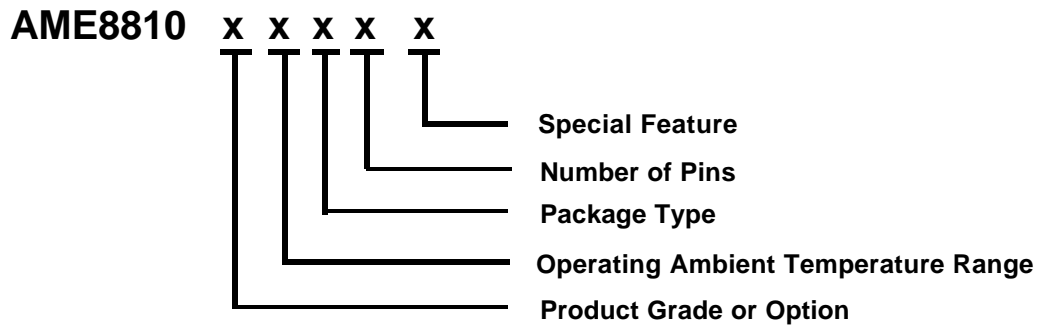
**■ Ordering Information**

Product Grade or Option	Operating Ambient Temperature Range	Package Type	Number of Pins	Special Feature
A: 3.3V    U: 3.2V B: 3.0V    V: 3.15V C: 2.8V    W: 2.3V D: 2.5V    Y: 1.9V E: 3.8V    Z: 1.7V F: 3.6V    1: 1.3V G: 3.5V    2: 2.0V H: 2.7V    3: 4.2V I: 3.4V    4: 4.0V J: 2.85V K: 3.7V L: 1.5V M: 1.8V N: 2.9V O: 3.1V P: 4.1V Q: 4.75V R: 2.65V S: 5.0V	E: -40°C to 85°C	G: SOT-223	T: 3	Z: Lead Free



■ Ordering Information (contd.)

Part Number	Marking*	Output Voltage	Package	Operating Ambient Temperature Range
AME8810AEGT	ADlyww	3.3V	SOT-223	- 40°C to + 85°C
AME8810AEGTZ	ADlyww	3.3V	SOT-223	- 40°C to + 85°C
AME8810BEGT	ADJyww	3.0V	SOT-223	- 40°C to + 85°C
AME8810BEGTZ	ADJyww	3.0V	SOT-223	- 40°C to + 85°C
AME8810CEGT	ADKyww	2.8V	SOT-223	- 40°C to + 85°C
AME8810CEGTZ	ADKyww	2.8V	SOT-223	- 40°C to + 85°C
AME8810DEGT	ADLyww	2.5V	SOT-223	- 40°C to + 85°C
AME8810DEGTZ	ADLyww	2.5V	SOT-223	- 40°C to + 85°C
AME8810EEGT	ADMyww	3.8V	SOT-223	- 40°C to + 85°C
AME8810EEGTZ	ADMyww	3.8V	SOT-223	- 40°C to + 85°C
AME8810FEGT	ADNyww	3.6V	SOT-223	- 40°C to + 85°C
AME8810FEGTZ	ADNyww	3.6V	SOT-223	- 40°C to + 85°C
AME8810GEGT	ADOyww	3.5V	SOT-223	- 40°C to + 85°C
AME8810GEGTZ	ADOyww	3.5V	SOT-223	- 40°C to + 85°C
AME8810HEGT	AEKyww	2.7V	SOT-223	- 40°C to + 85°C
AME8810HEGTZ	AEKyww	2.7V	SOT-223	- 40°C to + 85°C
AME8810IEGT	AESyww	3.4V	SOT-223	- 40°C to + 85°C
AME8810IEGTZ	AESyww	3.4V	SOT-223	- 40°C to + 85°C
AME8810JEGT	AGVyww	2.85V	SOT-223	- 40°C to + 85°C
AME8810JEGTZ	AGVyww	2.85V	SOT-223	- 40°C to + 85°C

Note: yww represents the date code.

\* A line on top of the first letter represents lead free plating such as  $\overline{AD}$ lyww.

Please consult AME sales office or authorized Rep./Distributor for output voltage and package type availability.



■ Ordering Information

Part Number	Marking*	Output Voltage	Package	Operating Ambient Temperature Range
AME8810KEGT	AHXyww	3.7V	SOT-223	- 40°C to + 85°C
AME8810KEGTZ	AHXyww	3.7V	SOT-223	- 40°C to + 85°C
AME8810LEGT	AJFyww	1.5V	SOT-223	- 40°C to + 85°C
AME8810LEGTZ	AJFyww	1.5V	SOT-223	- 40°C to + 85°C
AME8810MEGT	AJGyww	1.8V	SOT-223	- 40°C to + 85°C
AME8810MEGTZ	AJGyww	1.8V	SOT-223	- 40°C to + 85°C
AME8810NEGT	AKWyww	2.9V	SOT-223	- 40°C to + 85°C
AME8810NEGTZ	AKWyww	2.9V	SOT-223	- 40°C to + 85°C
AME8810OEGT	AKXyww	3.1V	SOT-223	- 40°C to + 85°C
AME8810OEGTZ	AKXyww	3.1V	SOT-223	- 40°C to + 85°C



■ Absolute Maximum Ratings

Parameter	Maximum	Unit
Input Voltage	8	V
Output Current	1	A
Input, Output Voltage	GND - 0.3 to $V_{IN} + 0.3$	V
ESD Classification	B*	

Caution: Stress above the listed absolute maximum rating may cause permanent damage to the device.

\*HBM B:2000V~3999V

■ Recommended Operating Conditions

Parameter	Symbol	Rating	Unit
Ambient Temperature Range	$T_A$	- 40 to + 85	°C
Junction Temperature Range	$T_J$	- 40 to + 125	°C

■ Thermal Information

Parameter	Package	Die Attach	Symbol	Maximum	Unit
Thermal Resistance* (Junction to Case)	SOT-223	Non-Conductive Epoxy	$\theta_{JC}$	31	°C / W
Thermal Resistance (Junction to Ambient)		Non-Conductive Epoxy	$\theta_{JA}$	135	°C / W
Internal Power Dissipation		Non-Conductive Epoxy	$P_D$	800	mW
Maximum Junction Temperature				150	°C
Solder Iron(10 Sec)**				350	°C

\* Measure  $\theta_{JC}$  on backside center of tab.

\*\* MIL-STD-202G 210F

**■ Electrical Specifications**

TA = 25°C unless otherwise noted

Parameter	Symbol	Test Condition	Min	Typ	Max	Units	
Input Voltage	$V_{IN}$		Note 1		7	V	
Output Voltage Accuracy	$V_O$	$I_O=1mA$	-1.5		1.5	%	
Dropout Voltage	$V_{DROPOUT}$	$I_O=600mA$ $V_O=V_{O(NOM)}-2.0%$	$1.3V \leq V_{O(NOM)} \leq 1.4V$	See chart	1900	mV	
			$1.4V < V_{O(NOM)} \leq 2.0V$		1400		
			$2.0V < V_{O(NOM)} \leq 2.8V$		800		
			$2.8V < V_{O(NOM)}$		600		
Output Current	$I_O$	$V_O > 1.2V$	600			mA	
Current Limit	$I_{LIM}$	$V_O > 1.2V$	600	800		mA	
Short Circuit Current	$I_{SC}$	$V_O < 0.8V$		300	600	mA	
Quiescent Current	$I_Q$	$I_O=0mA$		30	50	$\mu A$	
Ground Pin Current	$I_{GND}$	$I_O=1mA$ to 600mA		35		$\mu A$	
Line Regulation	$REG_{LINE}$	$I_O=1mA$ $V_{IN}=V_O+1$ to $V_O+2$	$1.3V \leq V_O \leq 1.4V$	-0.2		0.2	%
			$1.4V < V_O \leq 2.0V$	-0.15		0.15	
			$2.0V < V_O < 4.0V$	-0.1	0.02	0.1	
			$V_O \geq 4.0V$	-0.4	0.2	0.4	
Load Regulation	$REG_{LOAD}$	$I_O=1mA$ to 600mA		0.2	1	%	
Over Temperature Shutdown	OTS			150		$^{\circ}C$	
Over Temperature Hysteresis	OTH			30		$^{\circ}C$	
$V_O$ Temperature Coefficient	TC			30		ppm/ $^{\circ}C$	
Power Supply Rejection	PSRR	$I_O=100mA$ $C_O=2.2\mu F$	$f=100Hz$		60	dB	
			$f=1kHz$		50		
			$f=10kHz$		20		
Output Voltage Noise	eN	$f=10Hz$ to 100kHz $I_O=10mA, C_{BYP}=0\mu F$	$C_O=2.2\mu F$		30	$\mu V_{rms}$	

 Note1:  $V_{IN(MIN)}=V_{OUT}+V_{DROPOUT}$ 

Note2: To prevent the Short Circuit Current protection feature from being prematurely activated, the input voltage must be applied before a current source load is applied.



## ■ Detailed Description

The AME8810 of CMOS regulators contains a PMOS pass transistor, voltage reference, error amplifier, over-current protection, and thermal shutdown.

The P-channel pass transistor receives data from the error amplifier, over-current shutdown, and thermal protection circuits. During normal operation, the error amplifier compares the output voltage to a precision reference. Over-current and Thermal shutdown circuits become active when the junction temperature exceeds 150°C, or the current exceeds 600mA. During thermal shutdown, the output voltage remains low. Normal operation is restored when the junction temperature drops below 120°C.

The AME8810 switches from voltage mode to current mode when the load exceeds the rated output current. This prevents over-stress. The AME8810 also incorporates current foldback to reduce power dissipation when the output is short circuited. This feature becomes active when the output drops below 0.8 volts, and reduces the current flow by 65%. Full current is restored when the voltage exceeds 0.8 volts.

## ■ External Capacitors

The AME8810 is stable with an output capacitor to ground of 2.2 $\mu$ F or greater. Ceramic capacitors have the lowest ESR, and will offer the best AC performance. Conversely, Aluminum Electrolytic capacitors exhibit the highest ESR, resulting in the poorest AC response. Unfortunately, large value ceramic capacitors are comparatively expensive. One option is to parallel a 0.1 $\mu$ F ceramic capacitor with a 10 $\mu$ F Aluminum Electrolytic. The benefit is low ESR, high capacitance, and low overall cost.

A second capacitor is recommended between the input and ground to stabilize  $V_{in}$ . The input capacitor should be at least 0.1 $\mu$ F to have a beneficial effect.

All capacitors should be placed in close proximity to the pins. A "Quiet" ground termination is desirable. This can be achieved with a "Star" connection.



Ground Current vs. Input Voltage

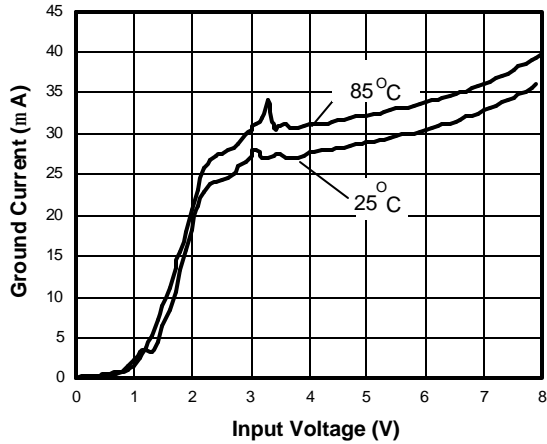

Load Step (1mA-600mA)

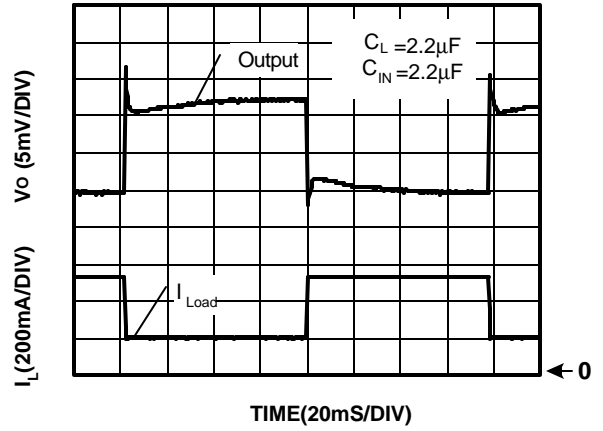

Drop Out Voltage vs. Output Voltage

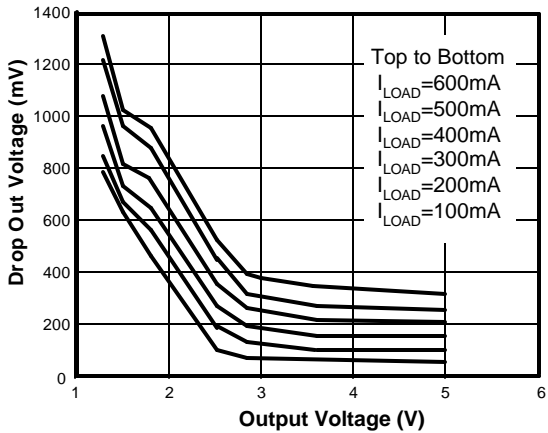

Power Supply Rejection Ratio

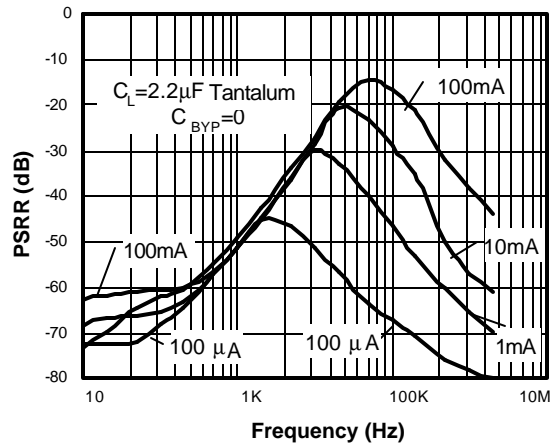

Safe Operating Area

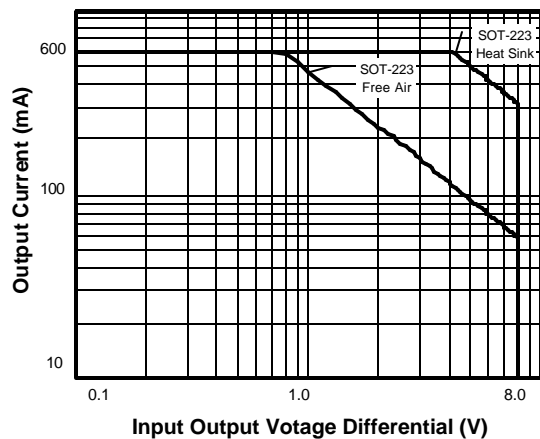

Line Transient Response

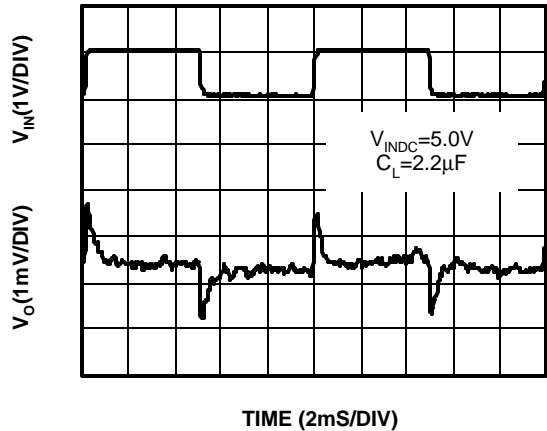



Noise Measurement

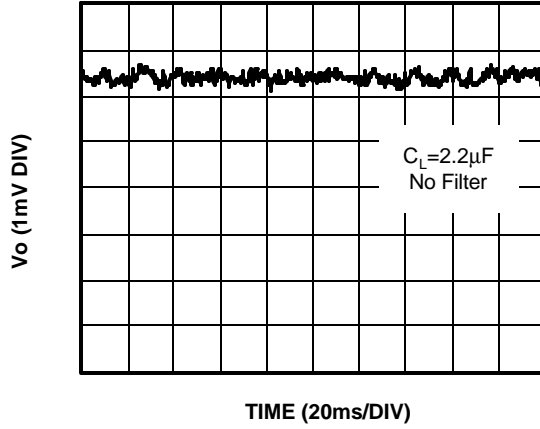

Overtemperature Shutdown

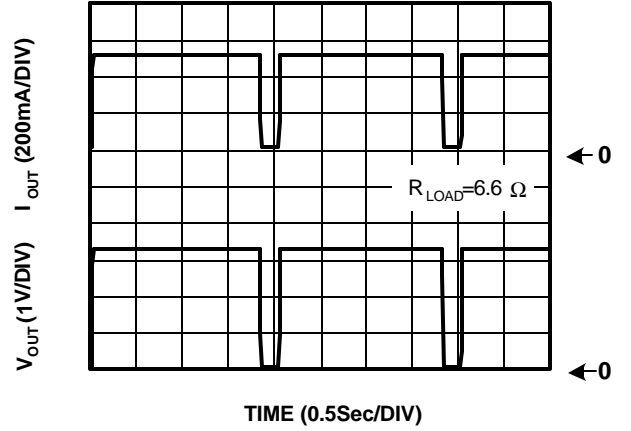

Current Limit Response

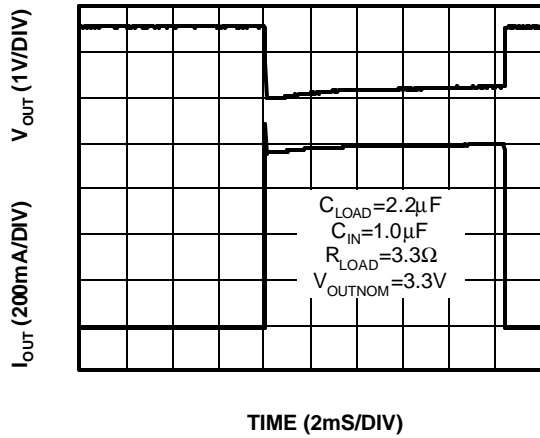

Short Circuit Response

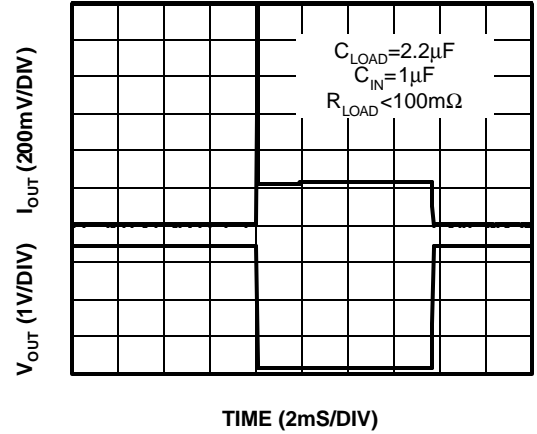

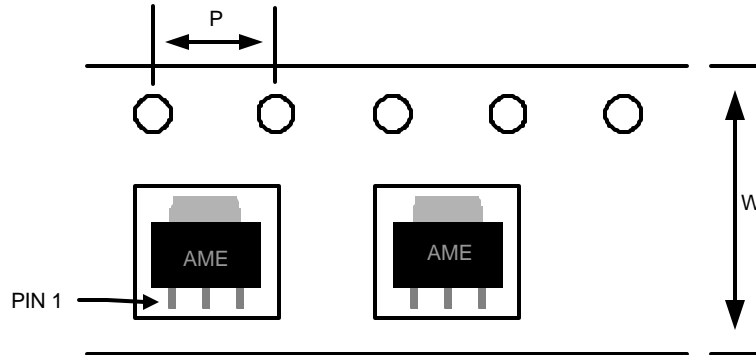
**■ Tape and Reel Dimension**
**SOT-223**

**Carrier Tape, Number of Components Per Reel and Reel Size**

Package	Carrier Width (W)	Pitch (P)	Part Per Full Reel	Reel Size
SOT-223	12.0±0.1 mm	4.0±0.1 mm	2500pcs	330±1 mm

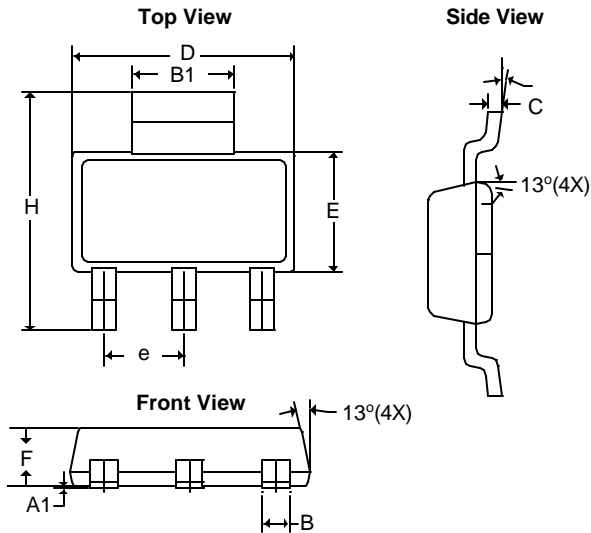

■ Package Dimension

SOT-223



SYMBOLS	MILLIMETERS		INCHES	
	MIN	MAX	MIN	MAX
$A_1$	0.01	0.10	0.0004	0.0039
$B$	0.60	0.84	0.0236	0.0330
$B_1$	2.90	3.15	0.1140	0.1240
$C$	0.24	0.38	0.0094	0.0150
$D$	6.30	6.71	0.2480	0.2640
$E$	3.30	3.71	0.1299	0.1460
$e$	2.30 BSC		0.0906 BSC	
$F$	1.40	1.80	0.0551	0.0709
$H$	6.70	7.30	0.2638	0.2874
$q$	$0^\circ$	$10^\circ$	$0^\circ$	$10^\circ$



**www.ame.com.tw**  
**E-Mail: sales@ame.com.tw**

Life Support Policy:

These products of AME, Inc. are not authorized for use as critical components in life-support devices or systems, without the express written approval of the president of AME, Inc.

AME, Inc. reserves the right to make changes in the circuitry and specifications of its devices and advises its customers to obtain the latest version of relevant information.

© AME, Inc. , April 2006

Document: 2006/2095-DS8810-A.01

**Corporate Headquarter**  
**AME, Inc.**

2F, 302 Rui-Guang Road, Nei-Hu District  
Taipei 114, Taiwan.  
Tel : 886 2 2627-8687  
Fax: 886 2 2659-2989

**U.S.A. (Subsidiary)**  
**Analog Microelectronics, Inc.**

3100 De La Cruz Blvd., Suite 201  
Santa Clara, CA. 95054-2046  
Tel: (408) 988-2388  
Fax: (408) 988-2489