

■ General Description

The AME78XX is a fixed output positive regulator. The regulator can provide local on card regulation, eliminating the distribution problems associated with single point regulation. The AME78XX can be used in logic systems, instrumentation, HiFi, and other solid state electronic equipments. When used as a Zener diode/resistor combination replacement, the AME78XX usually results in an effective output impedance improvement of two orders of magnitude, and lower quiescent current.

With adequate heat sinking the AME78XX can deliver 1A output current. Current limiting is included to limit the peak output current to a safe value.

The AME78XX is available in the plastic TO-220 and TO-252 packages.

■ Features

- Guaranteed 1A Output
- Fixed Output Voltage
- Typical Line Regulation $\leq 20\text{mV}$
- Accurate to Within $\pm 5\%$
- Internal Short Circuit Current-Limiting
- TO-220 and TO-252 Packages

■ Applications

- Post Regulation for Switching Supply
- Microprocessor Power Supply
- Mother Board I/O Power Supply
- Battery Power Circuit
- Instrument

■ Functional Block Diagram

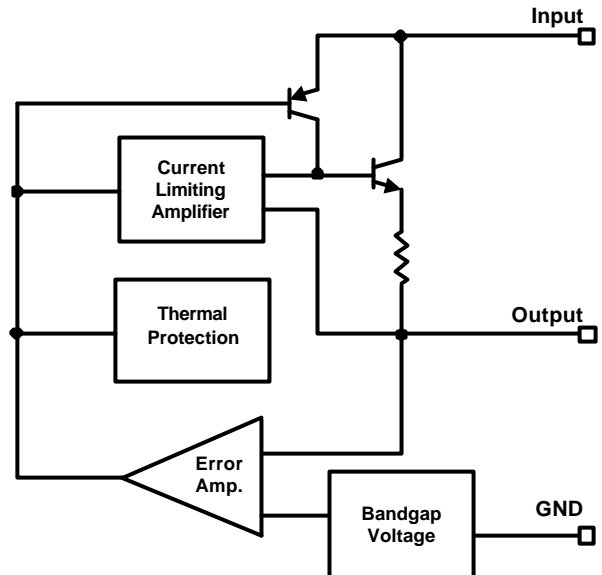

■ Typical Application

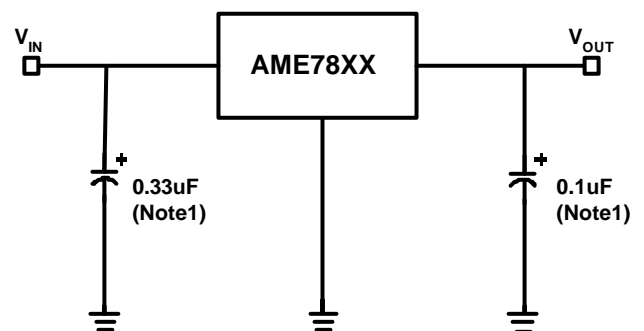

Note1: Bypass Capacitors are recommended for optimum stability and transient response and should be located as close as possible to the regulator

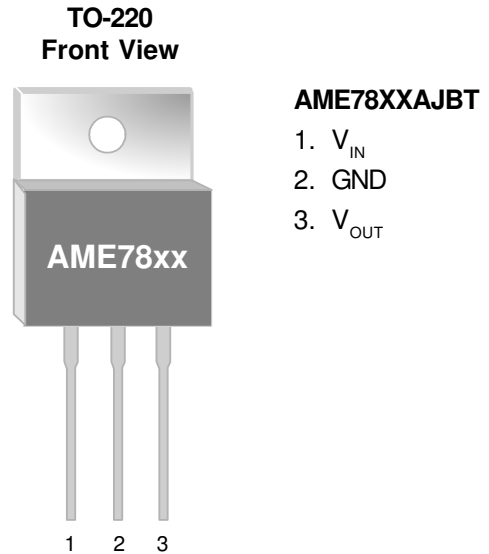
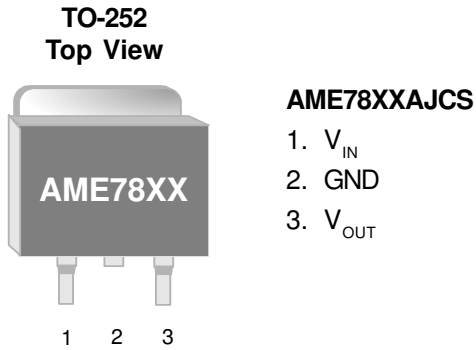
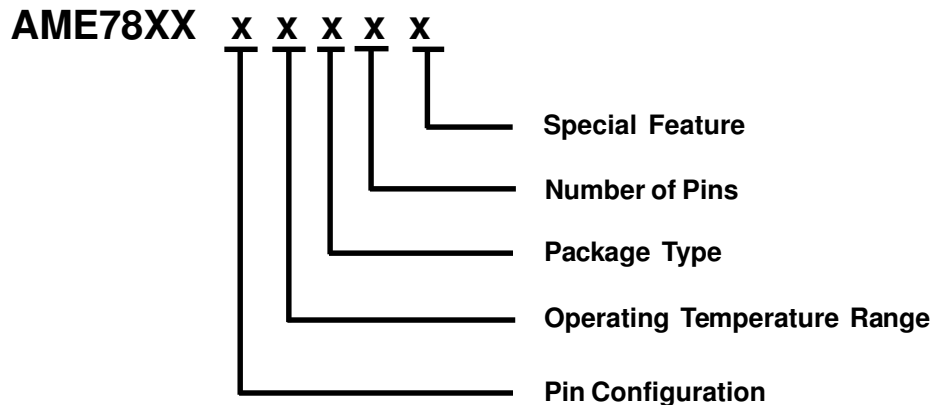
■ Pin Configuration

■ Ordering Information

Pin Configuration	Operating Temperature Range	Package Type	Number of Pins	Special Feature
A 1 . V_{IN} (TO-252) 2 . GND 3 . V_{OUT}	J: -40°C to 125°C	C: TO-252 B: TO-220	T: 3 S: 2	Z: Lead free
A 1 . V_{IN} (TO-220) 2 . GND 3 . V_{OUT}				

■ Ordering Information (contd.)

Part Number	Marking*	Output Voltage	Package	Operating Temp. Range
AME7805AJCS	AME7805 AJCS yyww	5V	TO-252	-40°C to 125°C
AME7805AJCSZ	AME7805 AJCS yyww	5V	TO-252	-40°C to 125°C
AME7805AJBT	AME7805 AJBT yyww	5V	TO-220	-40°C to 125°C
AME7805AJBTZ	AME7805 AJBT yyww	5V	TO-220	-40°C to 125°C
AME7808AJCS	AME7808 AJCS yyww	8V	TO-252	-40°C to 125°C
AME7808AJCSZ	AME7808 AJCS yyww	8V	TO-252	-40°C to 125°C
AME7808AJBT	AME7808 AJBT yyww	8V	TO-220	-40°C to 125°C
AME7808AJBTZ	AME7808 AJBT yyww	8V	TO-220	-40°C to 125°C
AME7809AJCS	AME7809 AJCS yyww	9V	TO-252	-40°C to 125°C
AME7809AJCSZ	AME7809 AJCS yyww	9V	TO-252	-40°C to 125°C
AME7809AJBT	AME7809 AJBT yyww	9V	TO-220	-40°C to 125°C
AME7809AJBTZ	AME7809 AJBT yyww	9V	TO-220	-40°C to 125°C

Note:ww & yyww represents date code

* a line on top of the first letter represents lead free plating such as \bar{A} ME.

Please consult AME sales office or authorized Rep./Distributor for voltage accuracy and package type availability.



■ Ordering Information (contd.)

Part Number	Marking*	Output Voltage	Package	Operating Temp. Range
AME7812AJCS	AME7812 AJCS yyww	12V	TO-252	-40°C to 125°C
AME7812AJCSZ	AME7812 AJCS yyww	12V	TO-252	-40°C to 125°C
AME7812AJBT	AME7812 AJBT yyww	12V	TO-220	-40°C to 125°C
AME7812AJBTZ	AME7812 AJBT yyww	12V	TO-220	-40°C to 125°C

■ Absolute Maximum Ratings

Parameter	Symbol	Maximum	Unit
Input Voltage	V_{IN}	20	V
Thermal Resistance (Junction to Ambient)	TO-220	50	°C/W
	TO-252	90	
Operating Junction Temperature Range	T_J	-40 to 125	°C
Storage Temperature Range	T_{STG}	- 65 to 150	
Lead Temperature (10 Sec)	T_{LEAD}	300	

■ Recommended Operating Conditions

Parameter	Rating	Unit
Operating Junction Temperature Range (T_J)	-40 to + 125	°C

■ Electrical Specifications-5V

Limits in standard typeface are for $T_j=25^\circ\text{C}$, $I_o=1\text{A}$, $C_I=0.33\mu\text{F}$, $C_o=0.1\mu\text{F}$, $V_I=10\text{V}$, unless otherwise specified.

Parameter	Symbol	Test Condition	Min	Typ	Max	Units
Output voltage	V_o		4.9	5	5.1	V
		$7.5\text{V} \leq V_{IN} \leq 15\text{V}$ $5\text{mA} \leq I_o \leq 1\text{A}$ (Note1)	* 4.8		* 5.2	
Line Regulation	Reg_{LINE}	$8.0\text{V} \leq V_{IN} \leq 15\text{V}$, $I_o=1\text{A}$		1	20	mV
Load Regulation	Reg_{LOAD}	$5\text{mA} \leq I_o \leq 1\text{A}$, $V_{IN}=10\text{V}$		10	35	mV
Quiescent Current	I_q	$V_{IN}=10\text{V}$		3.2	6.0	mA
Quiescent Current Change	I_q	$8.0\text{V} \leq V_{IN} \leq 15\text{V}$, $I_o=500\text{mA}$		0.3	* 0.8	mA
		$5\text{mA} \leq I_o \leq 1\text{A}$		0.08	* 0.5	
Output Voltage Noise	eN	$10\text{Hz} \leq f \leq 100\text{kHz}$ (Note2)		10		μV
Ripple Rejection	$\Delta V_{IN} / \Delta V_o$	$I_o=300\text{mA}$ $f=120\text{Hz}$, $8.0\text{V} \leq V_{IN} \leq 15\text{V}$	63	73		dB
Peak Output Current	I_{PK}	$V_{IN}=10\text{V}$		2.2		A
Short Circuit Current	I_{SC}	$V_{IN}=15\text{V}$		0.8		A
Average Temperature Coefficient of Output Voltage	$\Delta V_o / \Delta T$	$I_o=5.0\text{mA}$		-0.3		mV / $^\circ\text{C}$
Minimum Value of Input Voltage Required to Maintain Line Regulation	$V_{IN(\text{MIN})}$			7		V

Note1: Power Dissipation $\leq 15\text{W}$

Note2: Recommended minimum load capacitance of $0.01\mu\text{F}$ to limit high frequency noise.

■ Electrical Specifications-8V

Limits in standard typeface are for $T_j=25^{\circ}\text{C}$, $I_o=1\text{A}$, $C_I=0.33\mu\text{F}$, $C_O=0.1\mu\text{F}$, $V_I=14\text{V}$, unless otherwise specified.

Parameter	Symbol	Test Condition	Min	Typ	Max	Units
Output voltage	V_o		7.8	8	8.2	V
		$11\text{V} \leq V_{IN} \leq 15\text{V}$ $5\text{mA} \leq I_o \leq 1\text{A}$ (Note1)	* 7.7		* 8.3	
Line Regulation	Reg_{LINE}	$11\text{V} \leq V_{IN} \leq 15\text{V}$		2	26	mV
Load Regulation	Reg_{LOAD}	$5\text{mA} \leq I_o \leq 1\text{A}$, $V_{IN}=14\text{V}$		15	37	mV
Quiescent Current	I_Q	$V_{IN}=14\text{V}$		3.3	6.0	mA
Quiescent Current Change	I_Q	$11\text{V} \leq V_{IN} \leq 15\text{V}$, $I_o=500\text{mA}$			* 0.8	mA
		$5.0\text{mA} \leq I_o \leq 1\text{A}$			* 0.5	
Output Voltage Noise	eN	$10\text{Hz} \leq f \leq 100\text{kHz}$ (Note2)		10		μV
Ripple Rejection	$\Delta V_{IN} / \Delta V_O$	$I_o=300\text{mA}$ $f=120\text{Hz}$, $11\text{V} \leq V_{IN} \leq 15\text{V}$	56	62		dB
Peak Output Current	I_{PK}	$V_{IN}=13\text{V}$		2.2		A
Short Circuit Current	I_{SC}	$V_{IN}=15\text{V}$		0.8		A
Average Temperature Coefficient of Output Voltage	$\Delta V_O / \Delta T$	$I_o=5.0\text{mA}$		-0.4		$\text{mV} / ^{\circ}\text{C}$
Minimum Value of Input Voltage Required to Maintain Line Regulation	$V_{IN(\text{MIN})}$			10		V

Note1: Power Dissipation $\leq 15\text{W}$

Note2: Recommended minimum load capacitance of $0.01\mu\text{F}$ to limit high frequency noise.

■ Electrical Specifications-9V

Limits in standard typeface are for $T_j=25^\circ\text{C}$, $I_o=1\text{A}$, $C_l=0.33\mu\text{F}$, $C_o=0.1\mu\text{F}$, $V_i=15\text{V}$, unless otherwise specified.

Parameter	Symbol	Test Condition	Min	Typ	Max	Units
Output voltage	V_o		8.65	9	9.35	V
		$12\text{V} \leq V_{IN} \leq 15\text{V}$ $5\text{mA} \leq I_o \leq 1\text{A}$ (Note1)	* 8.55		* 9.45	
Line Regulation	Reg_{LINE}	$12\text{V} \leq V_{IN} \leq 15\text{V}$		1.8	24	mV
Load Regulation	Reg_{LOAD}	$5\text{mA} \leq I_o \leq 1\text{A}$, $V_{IN}=15\text{V}$		14	36	mV
Quiescent Current	I_Q	$V_{IN}=15\text{V}$		3.4	8.0	mA
Quiescent Current Change	I_Q	$12\text{V} \leq V_{IN} \leq 15\text{V}$, $I_o=500\text{mA}$			* 1.0	mA
		$5\text{mA} \leq I_o \leq 1\text{A}$			* 0.5	
Output Voltage Noise	eN	$10\text{Hz} \leq f \leq 100\text{kHz}$ (Note2)		10		μV
Ripple Rejection	$\Delta V_{IN} / \Delta V_O$	$I_o=300\text{mA}$ $f=120\text{Hz}$, $8.0\text{V} \leq V_{IN} \leq 15\text{V}$	56	61		dB
Peak Output Current	I_{PK}	$V_{IN}=14\text{V}$		2.2		A
Short Circuit Current	I_{SC}	$V_{IN}=15\text{V}$		0.8		A
Average Temperature Coefficient of Output Voltage	$\Delta V_O / \Delta T$	$I_o=5.0\text{mA}$		-0.50		$\text{mV} / ^\circ\text{C}$
Minimum Value of Input Voltage Required to Maintain Line Regulation	$V_{IN(\text{MIN})}$			11		V

Note1: Power Dissipation $\leq 15\text{W}$

Note2: Recommended minimum load capacitance of $0.01\mu\text{F}$ to limit high frequency noise.

■ Electrical Specifications-12V

Limits in standard typeface are for $T_j=25^\circ\text{C}$, $I_o=1\text{A}$, $C_I=0.33\mu\text{F}$, $C_O=0.1\mu\text{F}$, $V_I=17\text{V}$, unless otherwise specified.

Parameter	Symbol	Test Condition	Min	Typ	Max	Units
Output voltage	V_o		11.5	12	12.5	V
		$15\text{V} \leq V_{IN} \leq 17\text{V}$ $5\text{mA} \leq I_o \leq 1\text{A}$ (Note1)	* 11.4		* 12.6	
Line Regulation	Reg_{LINE}	$15\text{V} \leq V_{IN} \leq 17\text{V}$		2.2	20	mV
Load Regulation	Reg_{LOAD}	$5\text{mA} \leq I_o \leq 1\text{A}$, $V_{IN}=17\text{V}$		8.1	60	mV
Quiescent Current	I_Q	$V_{IN}=17\text{V}$		3.4	6.5	mA
Quiescent Current Change	I_Q	$15\text{V} \leq V_{IN} \leq 17\text{V}$, $I_o=1\text{A}$			* 0.7	mA
		$5\text{mA} \leq I_o \leq 1\text{A}$			* 0.5	
Output Voltage Noise	eN	$10\text{Hz} \leq f \leq 100\text{kHz}$ (Note2)		10		μV
Ripple Rejection	$\Delta V_{IN} / \Delta V_O$	$I_o=300\text{mA}$ $f=120\text{Hz}$, $15\text{V} \leq V_{IN} \leq 18\text{V}$	55	60		dB
Peak Output Current	I_{PK}	$V_{IN}=17\text{V}$		2.2		A
Short Circuit Current	I_{SC}	$V_{IN}=15\text{V}$		0.8		A
Average Temperature Coefficient of Output Voltage	$\Delta V_O / \Delta T$	$I_o=5.0\text{mA}$		-0.80		mV / $^\circ\text{C}$
Minimum Value of Input Voltage Required to Maintain Line Regulation	$V_{IN(\text{MIN})}$			14		V

Note1: Power Dissipation $\leq 15\text{W}$

Note2: Recommended minimum load capacitance of 0.01 μF to limit high frequency noise.



Output Voltage vs. Input Voltage

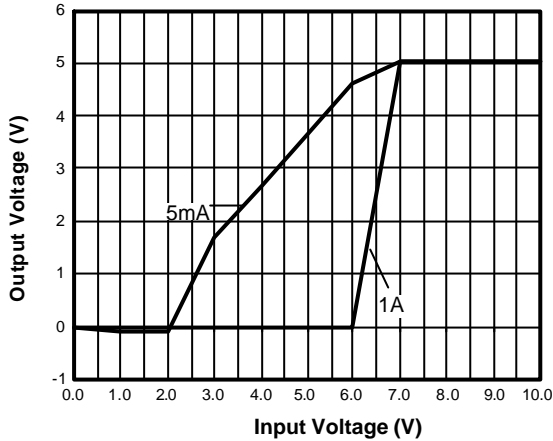

Dropout Voltage vs. Temperature

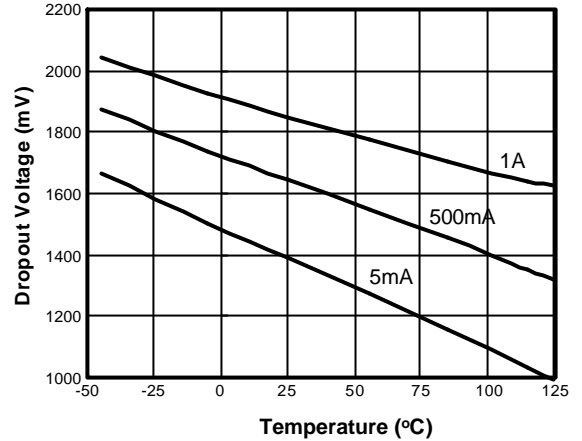

Quiescent Current vs. Input Voltage

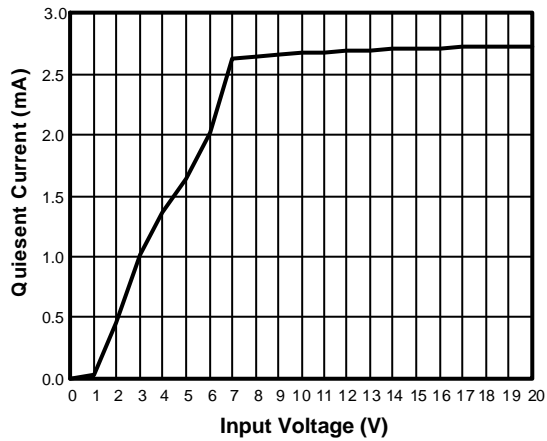

Dropout Voltage vs. Load Current

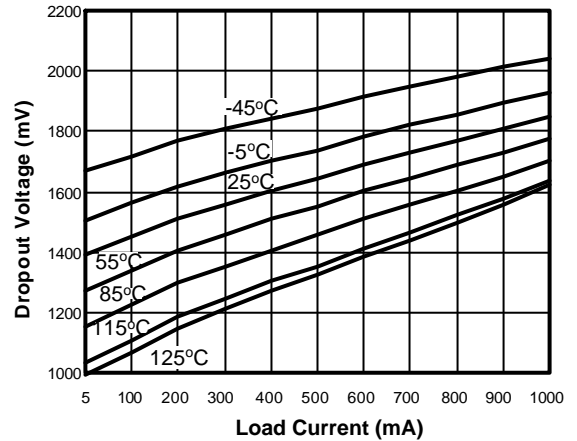

Quiescent Current vs. Temperature

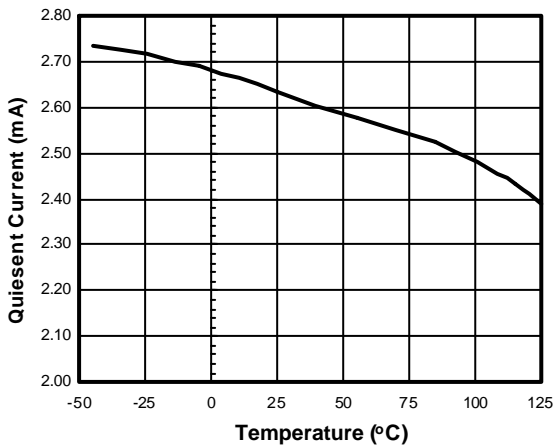

Load Regulation vs. Temperature

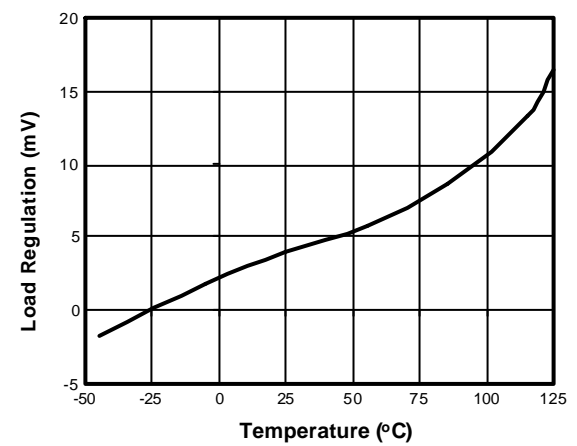



Output Voltage vs. Temperature

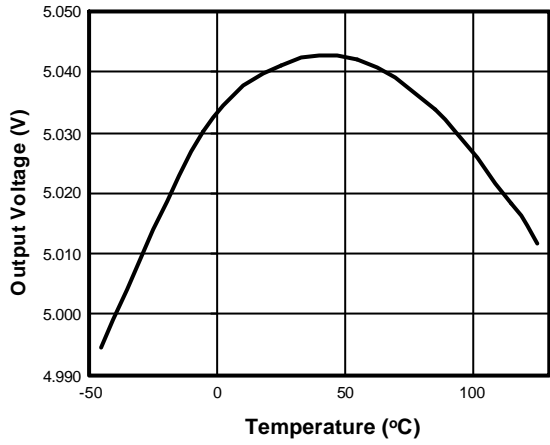

Short Circuit Current vs. Temperature

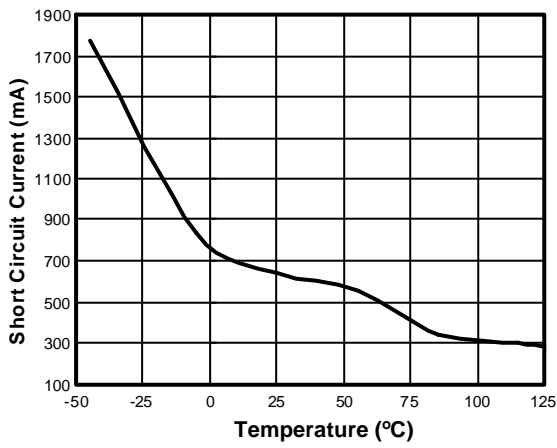



■ Package Dimension

TO-252

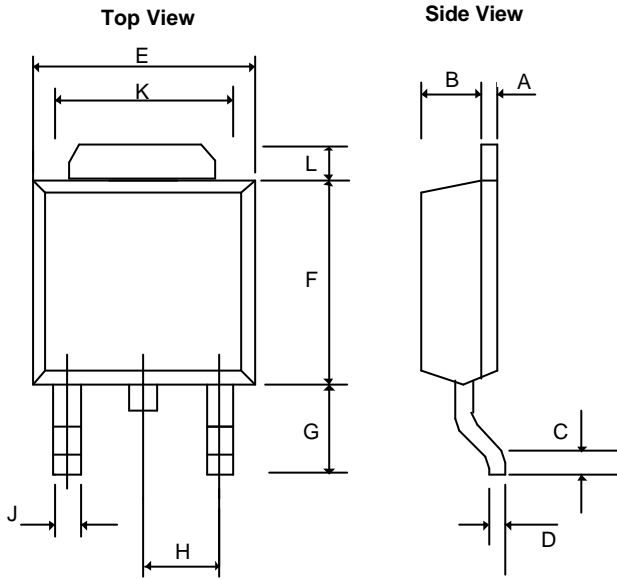

SYMBOLS	MILLIMETERS		INCHES	
	MIN	MAX	MIN	MAX
A	0.43	0.58	0.0169	0.0230
B	1.60	1.95	0.0630	0.0768
C	0.51	1.78	0.0200	0.0701
D	0.43	0.60	0.0169	0.0236
E	6.35	6.80	0.2500	0.2677
F	5.36	7.20	0.2110	0.2835
G	2.20	3.00	0.0866	0.1181
H	-	* 2.30	-	*0.0906
J	-	0.97	-	0.0380
K	5.20	5.50	0.2047	0.2165
L	1.40REF		0.055REF	

*: Typical Value

Notes:

1. Controlling dimension: Millimeters.
2. Maximum lead thickness includes lead finish thickness. Minimum lead thickness is the minimum thickness of base material.

TO-220

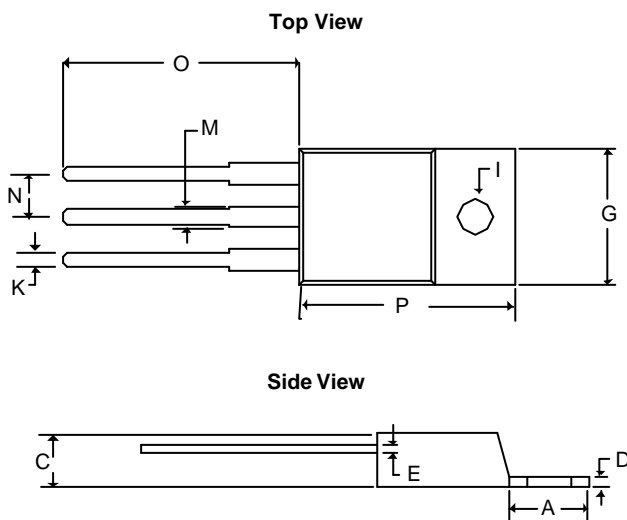

SYMBOLS	MILLIMETERS		INCHES	
	MIN	MAX	MIN	MAX
A	5.58	7.49	0.2197	0.2949
C	2.03	4.83	0.0800	0.1902
D	0.50	1.40	0.0197	0.0550
E	0.30	1.15	0.0118	0.0453
G	9.65	10.67	0.3799	0.4200
I	3.53	4.09	0.1390	0.1610
K	0.50	1.15	0.0197	0.0453
M	1.14	1.78	0.0449	0.0700
N	2.28	2.80	0.0898	0.1102
O	12.70	14.74	0.5000	0.5803
P	14.22	16.51	0.5600	0.6500



www.ame.com.tw
E-Mail: sales@ame.com.tw

Life Support Policy:

These products of AME, Inc. are not authorized for use as critical components in life-support devices or systems, without the express written approval of the president of AME, Inc.

AME, Inc. reserves the right to make changes in the circuitry and specifications of its devices and advises its customers to obtain the latest version of relevant information.

© AME, Inc. , June 2005

Document: BCD-DS78XX-B

Corporate Headquarter
AME, Inc.

2F, 302 Rui-Guang Road, Nei-Hu District
Taipei 114, Taiwan.

Tel: 886 2 2627-8687

Fax: 886 2 2659-2989

U.S.A.(Subsidiary)
Analog Microelectronics, Inc.

3100 De La Cruz Blvd., Suite 201
Santa Clara, CA. 95054-2046

Tel : (408) 988-2388

Fax: (408) 988-2489